

Panasonic®

Electronic Board

Operating Instructions With Installation Manual (for qualified service personnel)



[Stand (option)]



[Wall-mounting]

The unit in this picture is UB-5315 series.
(Stand kit is optional.)

Model No. **UB-5315**
UB-5815

Panaboard

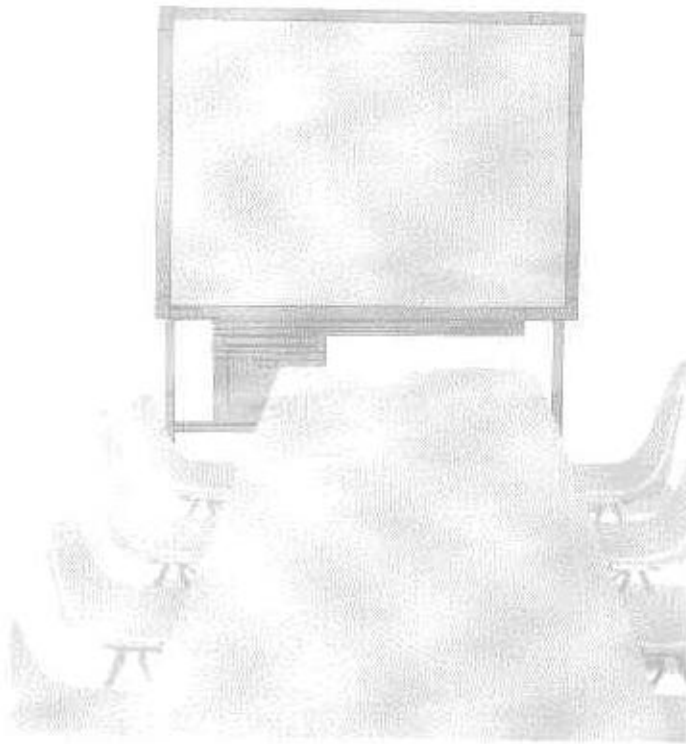

- Before operating this unit, please read these instructions completely.
After reading them, preserve them carefully for future reference.
- Because of the nature of the print film, all the printed text will remain on the film.
- This product is designed for installation by a qualified servicing dealer.
Installation performed by non-authorized individuals could cause safety-related problems with the operation of this equipment.
- To locate the closest authorized dealer in your area, please call 1-800-449-8988.

Thank you for purchasing the Panasonic Electronic Board.
For optimum performance and safety, please read these instructions carefully.

Accessories

	Q'ty		Q'ty
• Thermal transfer film	1	• Letter size copy paper	20
• Markers (red, black, and blue)	1 each	• Software CD-ROM	1
• Operating Instructions	1	• Software License Agreement	1
• Eraser	1	• Warranty card	1
• Power cord	1		

* The stand is optional. By way of example, this manual describes an Electronic Board which is used with the stand.
* USB cable is not included.

Things you should keep a record of

Attach your sales receipt here

For your future reference

Date of purchase: _____ Serial number: _____

Dealer's name and address: _____

Dealer's address: _____ Tel: _____

Federal Communications Commission Requirements

Note: This equipment has been tested and found to comply with the limits for a Class A digital device, pursuant to part 15 of the FCC Rules. These limits are designed to provide reasonable protection against harmful interference when the equipment is operated in a commercial environment. This equipment generates, uses, and can radiate radio frequency energy and, if not installed and used in accordance with the instruction manual, may cause harmful interference to radio communications. Operation of this equipment in a residential area is likely to cause harmful interference in which case the user will be required to correct the interference at his own expense.

FCC Warning: To assure continued FCC compliance, the user must use only the provided power supply cord. Also, any unauthorized changes or modifications to this equipment would void the user's authority to operate this device.

- Microsoft, Windows and Windows NT are either registered trademarks or trademarks of Microsoft Corporation in the United States and/or other countries.
Windows® is Microsoft® Windows® operating system.
Screen shots reprinted with permission from Microsoft Corporation.
- IBM is a registered trademark of International Business Machines Corporation.
- Pentium is a registered trademark of Intel Corporation in the U.S. and other countries.
- Adobe and Acrobat are registered trademarks of Adobe Systems Incorporated.
- All trademarks referred to in this manual are property of their respective companies.

The information given in this Operating Instructions is subject to change without notice.

Table of Contents

Page

Before You Start

For Your Safety	4
Precautions	5
• CD-ROM	6
Part Names and Functions	8
• Control panel	9

Using

Installing the Thermal Transfer Film	10
Loading Copy Paper	12
Making Copies	14
• Copy types and procedures	15
Replacing the Thermal Transfer Film	16
Paper Jams	17
Screen Height Adjustment	20
Computer Interfacing	22
• System requirements	22
• Contents of CD-ROM	22
• Connecting the unit to a computer	22
• Installing the driver and software	23
• Removing the driver and software	29
• Scanning	29
• Panaboard Operation Panel	30
• Printing	31

Help

Daily Care and Maintenance	32
• Cleaning the screen and the unit	32
• Caring for the eraser	32
• Cleaning the printer head, platen roller and pick-up roller	32
Troubleshooting	34
• Meanings of error codes	35
Specifications	36
• Option and Separately available	36

Warning about saving data

When the system storage device or any of its optional storage device is adversely effected by operational errors, static electricity, electrical noise, vibration, dust or when the power has been cut off due to malfunction, repair or inadvertently, the memory contents may be lost or changed. Before operating the system, make a point of reading the precautionary notes in the Operating Instructions and the help information, and observe them during operation.

Please observe carefully the following precaution:

- Make absolutely sure that all important data is saved by back-up or the original is saved.

The manufacturer hereby declares that it cannot be held accountable for any loss or change in any data stored on floppy disks, hard disks, optical disks, or other memory devices.

For Your Safety

CAUTION:

TO PREVENT RISK OF ELECTRIC SHOCK HAZARD, DO NOT REMOVE THE COVER OF THIS PRODUCT, REFER SERVICING TO QUALIFIED SERVICE PERSONNEL.

WARNING:

TO PREVENT FIRE OR SHOCK HAZARD, DO NOT EXPOSE THIS PRODUCT TO RAIN OR ANY TYPE OF MOISTURE.

THE SOCKET-OUTLET MUST BE NEAR THIS EQUIPMENT AND MUST BE EASILY ACCESSIBLE.

The product should be used only with the power cord that is supplied by the manufacturer.

CLASS 1 LED PRODUCT

Precautions

Never remove the cover, take apart or modify the product. This will void the warranty.

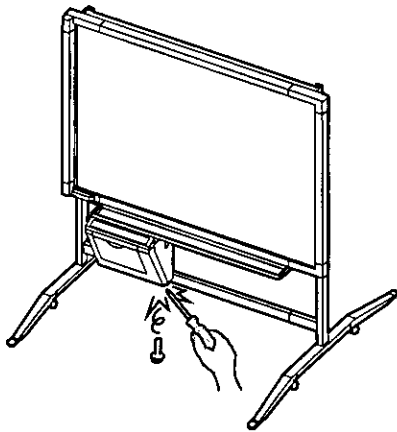

Do not position the electronic board in a location where it is unstable.

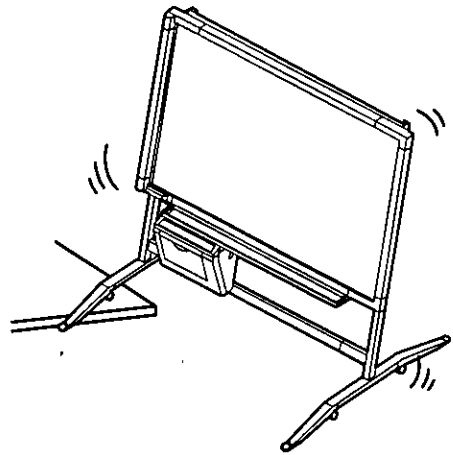

Do not put drinks, other liquids or heavy items on the tray or screen.

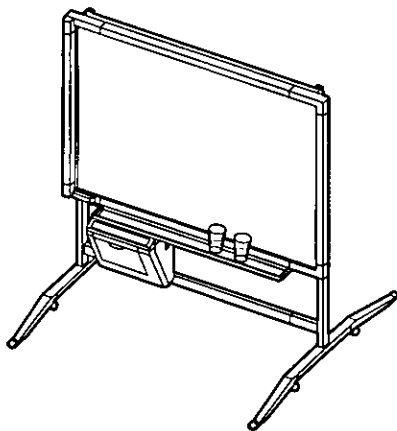

After installing or moving the electronic board, lock the casters and set the fall-prevention extension legs.

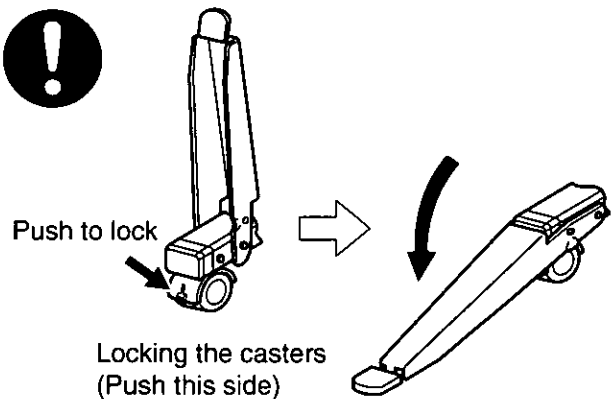

Do not use the electronic board in an excessively humid or dusty location.

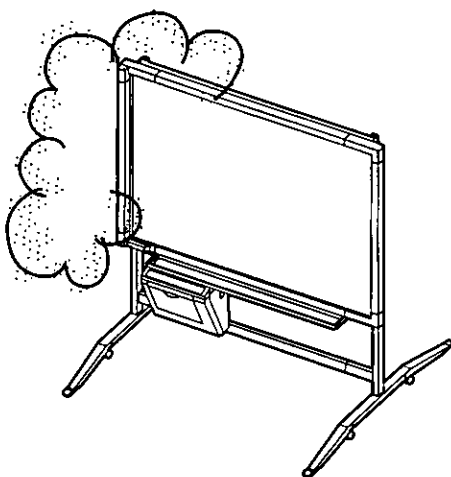

If the electronic board is not going to be used for an extended period of time (e.g., during extended holidays), turn off the power and remove the plug from the wall outlet.

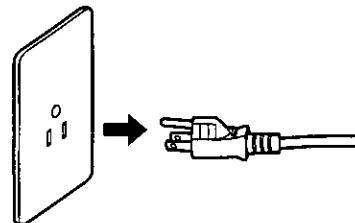

Precautions

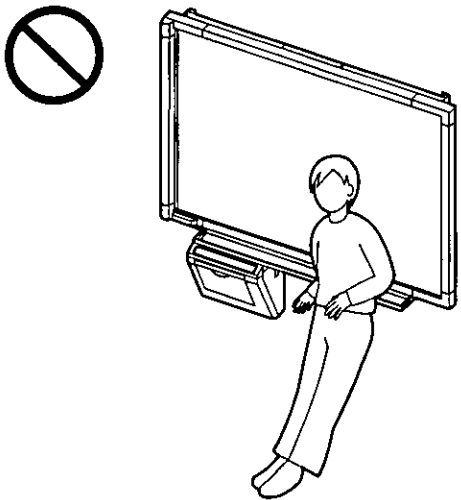
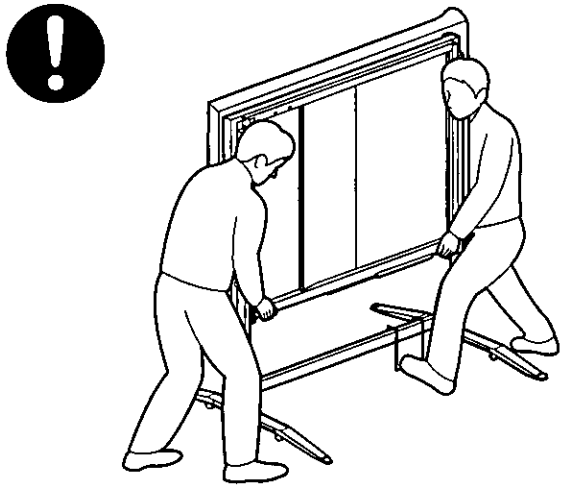
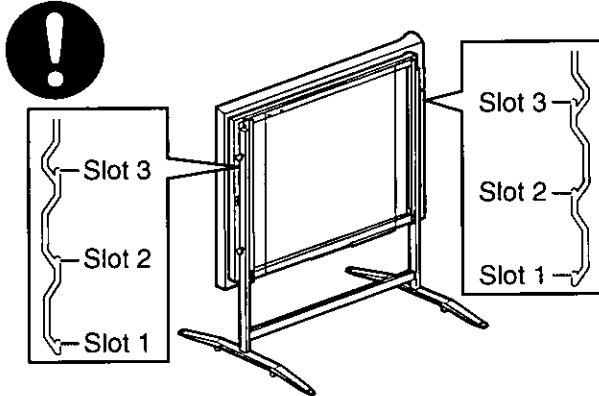
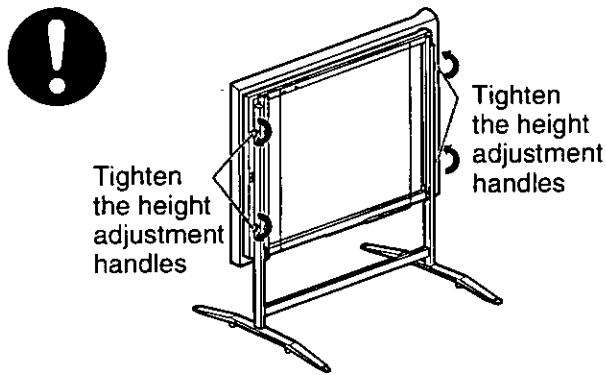
<p>Do not lean against the screen or on the cover (lower), even if the electronic board is mounted on the wall.</p> 	<p>The screen height must be adjusted by two people.</p> 
<p>Confirm both sides of the screen are hung in the same height slots.</p> 	<p>Make sure to tighten the height adjustment handles after adjusting the screen height.</p> 

■ CD-ROM

To prevent the CD-ROMs from accidental damages:

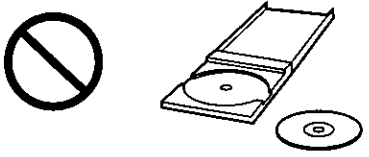
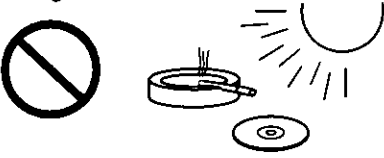
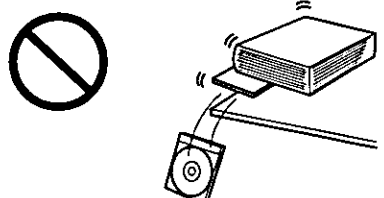
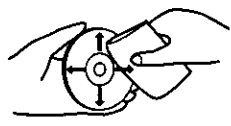
<p>Do not touch or write on the surface of the disc.</p> 	<p>Do not leave the disc out of the protective case.</p> 	<p>Do not leave the disc in direct sunlight or near heat sources.</p> 
<p>Do not place heavy objects on the disc case or drop the case.</p> 	<p>To clean the disc, hold the disc by its edges and wipe it from the center to the edges with a dry, soft cloth.</p> 	

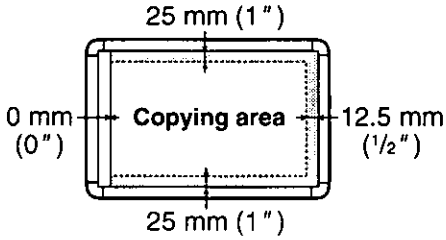
Installation	<ul style="list-style-type: none"> • Do not install the unit where it may be exposed to direct sunlight, near heating equipment, or near air-conditioning vents as this may cause stretching and/or discoloration of the screen. • Do not install the unit in strong sunlight or strong lighting. Proper copying may become impossible. • Do not install the unit in locations where the temperature may change suddenly as this may disable the unit's ability to make copies.
Screen Film	<ul style="list-style-type: none"> • Make thick and dark lines inside the copying area. Note that any writing inside the shaded area (on right) cannot be copied. • Do not allow writing to remain on the screen for an extended period of time as it will become harder to erase. • Do not touch the screen, write with markers, or erase while the screen is moving as this may result in damage to the unit. <div style="text-align: center; margin-top: 10px;">  <p>The diagram shows a rectangular screen with a central 'Copying area' defined by a dashed line. The overall width and height of the screen are both 25 mm (1 inch). A 12.5 mm (1/2 inch) margin is shown on the right side, and a 0 mm (0 inch) margin is shown on the left side.</p> </div>
Markers, Erasers and Thermal Transfer Film	<ul style="list-style-type: none"> • Use only the included or designated markers, erasers and thermal transfer film. (See page 36.) Use of accessories other than those included or designated (such as oil-based markers) may damage the screen or result in hard-to-erase markings. • Do not store the thermal transfer film in a location subject to extreme changes in temperature (such as near air conditioning or heating equipment) as this may cause condensation on the thermal transfer film and result in poor print quality and/or paper jams. • The length of one roll of designated thermal transfer film (Replacement film: UG-6001) is approximately 50 meters (164 ft.). One roll of thermal transfer film can make approximately 150 sheets of copies. Note that the total number of copies may differ depending on the operating conditions. Also note that the length of the thermal transfer film supplied with the unit is shorter than the replacement film roll and is only approximately 10 meters (32.8 ft.). • Store markers horizontally as vertical storage may stop the ink from coming out.
Power Cord	<ul style="list-style-type: none"> • When moving the unit, disconnect the power cord from the electrical power socket and from the printer's power connector and coil it for transportation as stepping on the power cord or having it catch on something during movement may result in damage to the cord.
Replacing the Thermal Transfer Film	<ul style="list-style-type: none"> • Dispose of the used thermal transfer film in a trash receptacle for burnable trash. • A negative of the copied image will remain on the thermal transfer film. (To protect the security of your information, we recommend cutting up the used thermal transfer film with scissors or shredder before disposing of it.)
USB Cable	<ul style="list-style-type: none"> • Use a shielded USB cable that is certified as logo by USB-IF. • If you connect the electronic board to a USB hub, it is not guaranteed to work.

Part Names and Functions

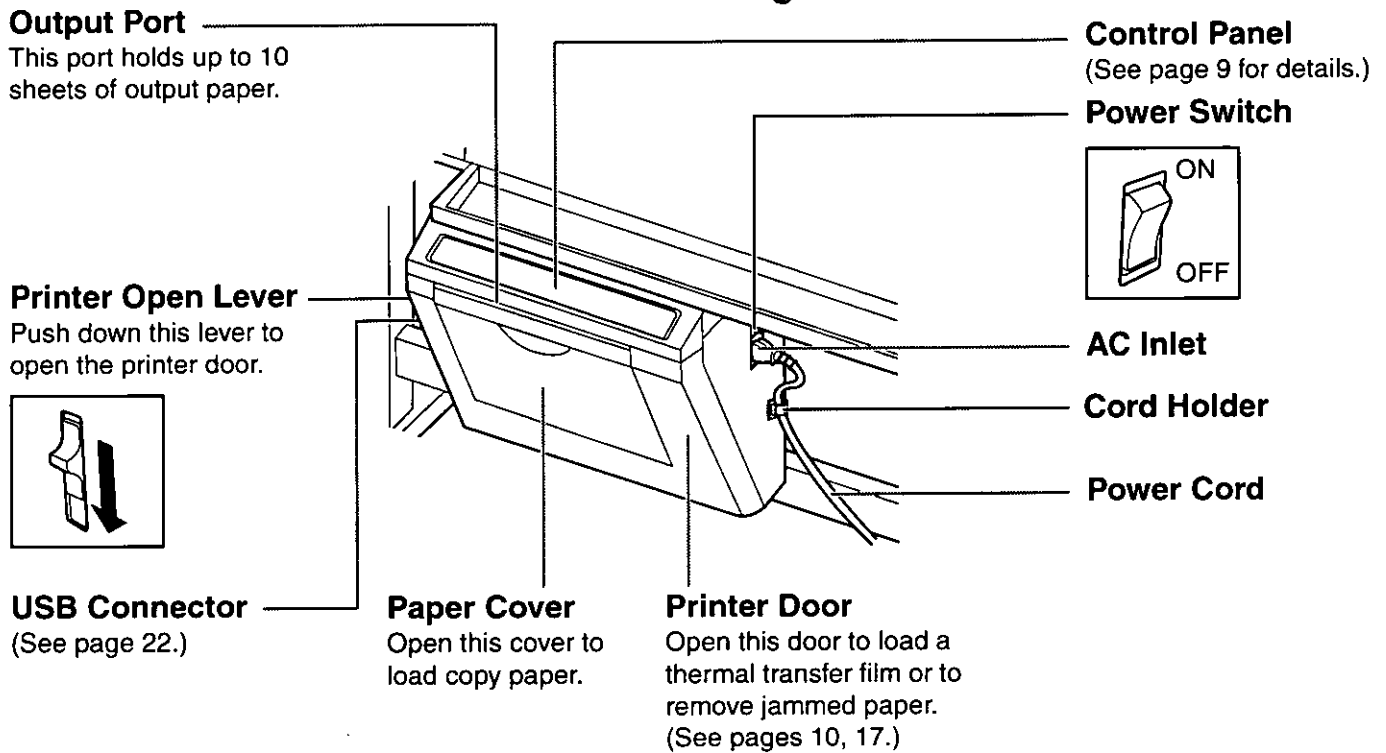
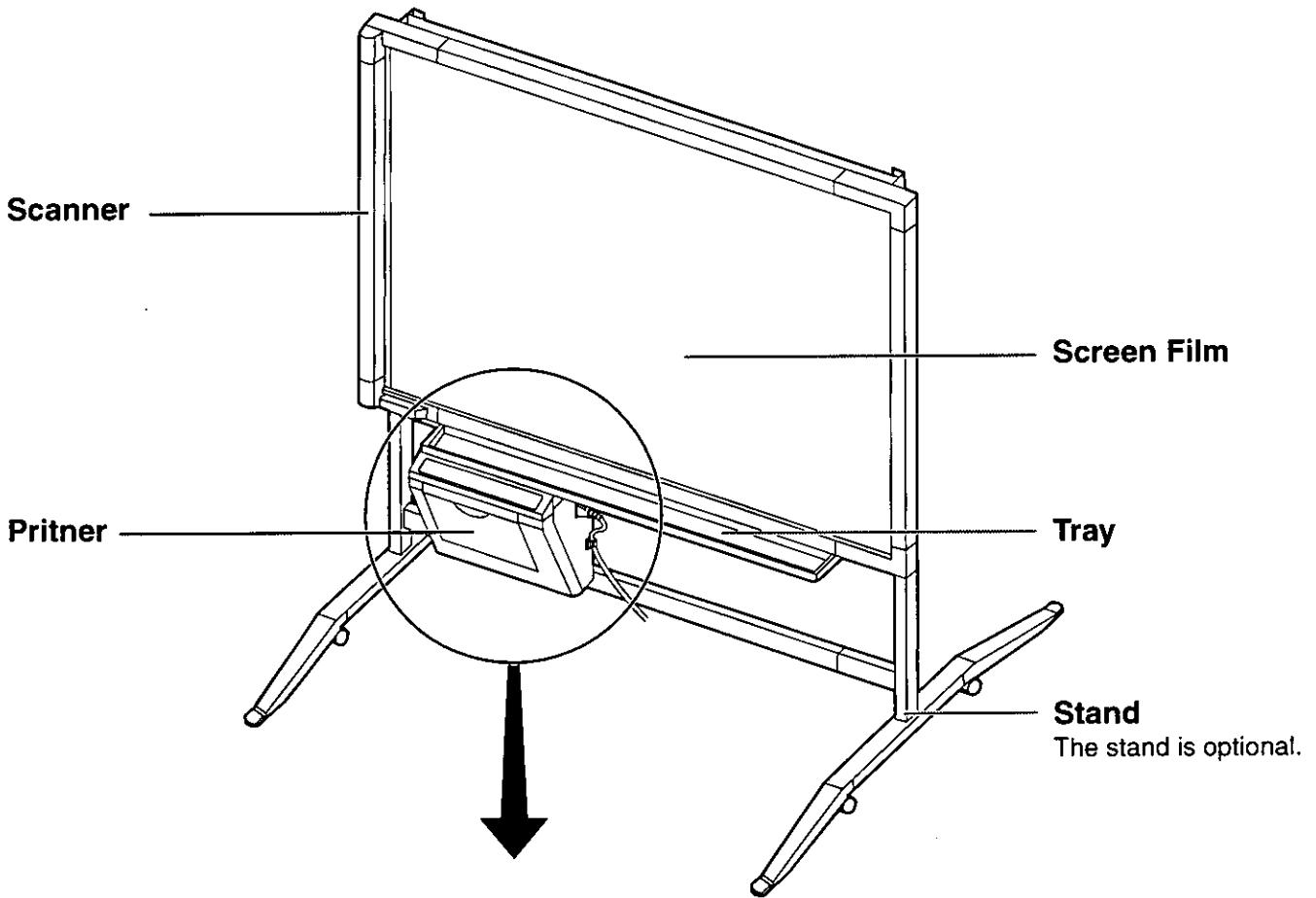

■ Control panel

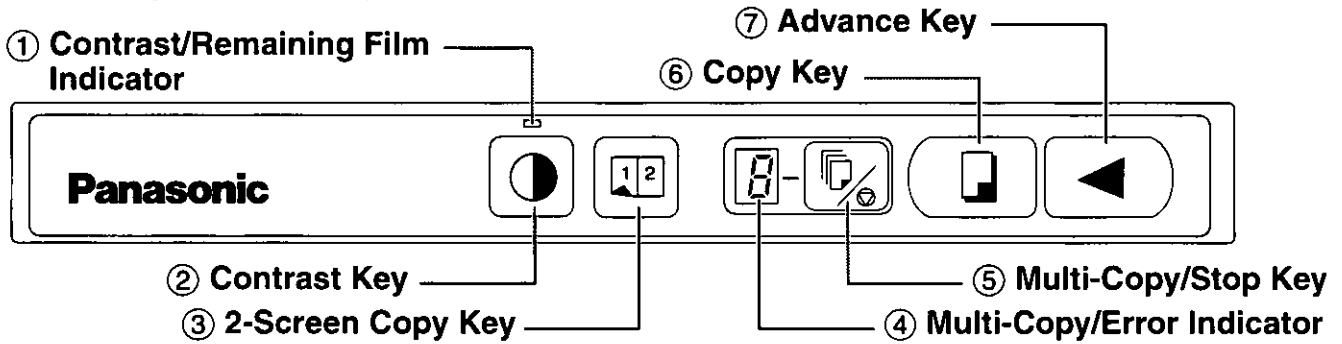

Panel	Name	Description
	① Contrast/Remaining Film Indicator	This lamp indicator notifies the user when the time to replace the thermal transfer film is approaching (estimated) and of the printing contrast used during copying. Indicator off: Normal printing contrast Indicator on: Darker than normal printing contrast Indicator flashing*: Almost time to replace the thermal transfer film (Note that only about 15 more sheets may be copied when this indicator starts flashing.) Replacement film (UG-6001) is separately available from the dealer where you purchased your unit. * The flashing indicator will go out after the power is turned off and the printer has been opened and closed. (When copying is performed, this indicator will begin flashing again.)
	② Contrast Key	Each time this key is pressed, the unit will alternate between normal and dark contrast modes (Normal/Dark).
	③ 2-Screen Copy Key	This key causes the front and back of the screen to be copied on a single sheet of paper.
	④ Multi-Copy/Error Indicator	This indicator displays the number of copies to be made. The display changes each time the Multi-Copy/Stop Key is pressed. Example: 1 → 2 → ... → 9 → 1 → ... When an error occurred, a flashing symbol will appear in this display to indicate the error status. (See page 35.)
	⑤ Multi-Copy/Stop Key	When making multiple copies, press this key until the desired number of copies is displayed on the Multi-Copy/Error Indicator. This key can also be pressed while multiple copies are being made to stop the copying process. The display indication changes while multiple copies are being made as shown below. After reaching 0, the display will reset to 1. Example: 5 → 4 → 3 → 2 → 1 → 0 → 1 (countdown display during copying)
	⑥ Copy Key	This key causes the screen to be copied.
	⑦ Advance Key	This key advances the screen from right to left.

Installing the Thermal Transfer Film

Install the thermal transfer film in the printer.

1

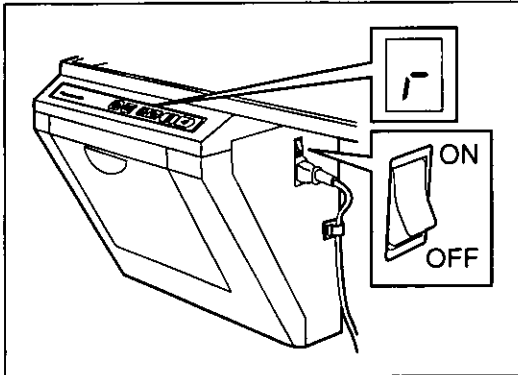

Set the power switch to on (I).

- “ r ” will flash on the Multi-Copy/Error Indicator when the thermal transfer film has run out.

2

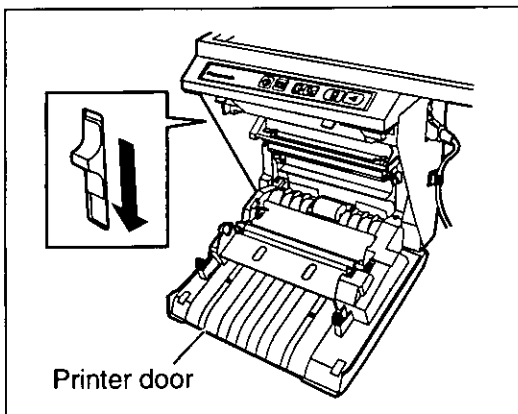

Push down the printer open lever and open the printer door.

3

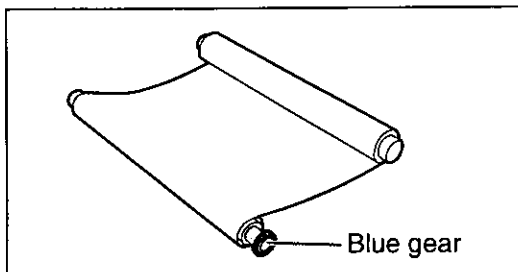

Install the thermal transfer film.

- 1) Set the thermal transfer film, with the blue gear in front, on the right.

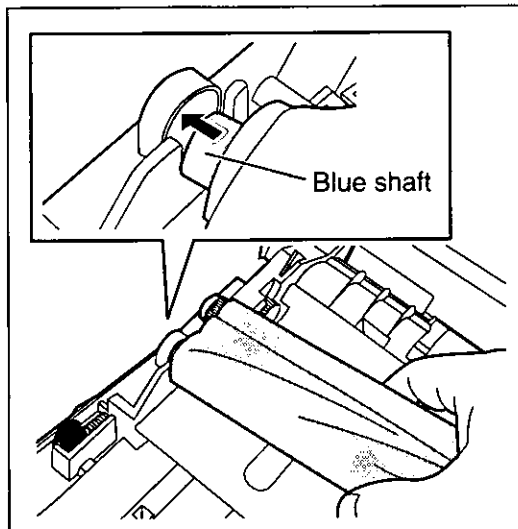

- 2) Insert the blue shaft into the front left hole.

Installing the Thermal Transfer Film

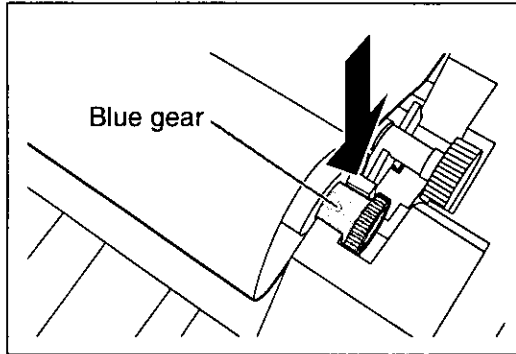

3) Place the blue gear on the front right groove.

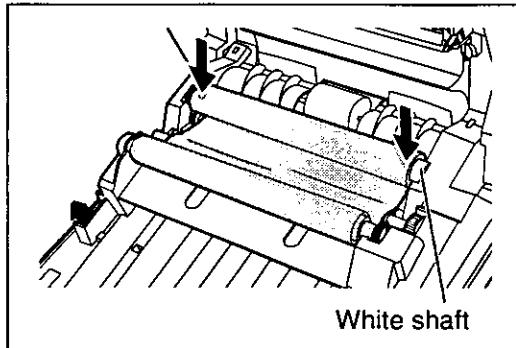

4) Place the white shaft on both sides of the back grooves.

4

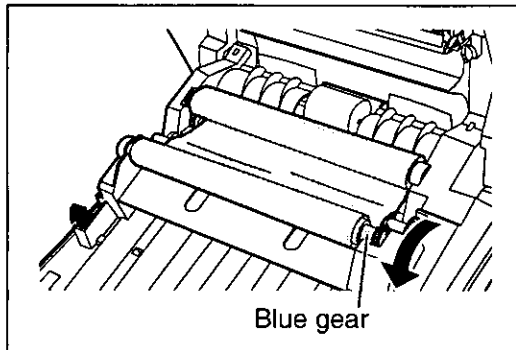

Tighten the film, then close the printer door.

1) Rotate the blue gear in the direction of the arrow to take up the slack on the film.

- If a slack remains, perform step 3-2) through 4-1) again.

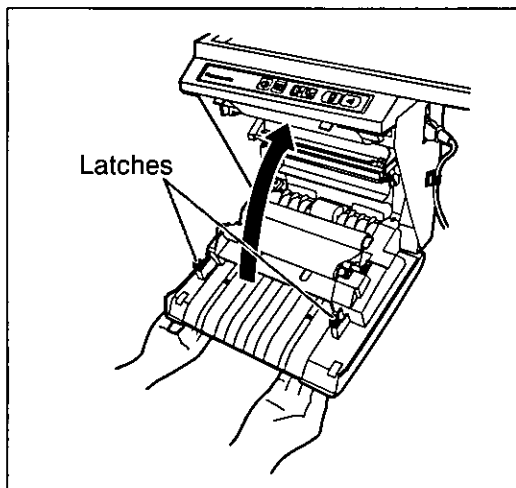

2) Securely close the printer door by using both hands until a click is heard.

- “r” flashing on the Multi-Copy/Error Indicator will go out.

Notes

- If “r” is still flashing after closing the printer door, make sure that the thermal transfer film has been installed properly and tightened.
- The printer door should be closed to make copies properly. Confirm both latches are locked.

Loading Copy Paper

It is possible to load up to 40 sheets of Letter size copy paper (assuming a paper weight of 80 g/m²).

Note that only Letter size paper may be used.

When the unit is first used or when "P" flashes on the Multi-Copy/Error Indicator to indicate that the unit is out of paper, load copy paper as described below.

Notes on Loading Copy Paper

Follow the guidelines below to ensure smooth and accurate printing by the unit.

- Only use Letter size copy paper having a weight of 60 to 90 g/m² as the copy paper for this unit.
- Do not simultaneously load paper of varying type and thickness as this may result in paper jams.
- Before adding copy paper, be sure to remove all the copy paper remaining inside the unit's paper cover. (Note that copy paper will slightly resist being removed, but may be pulled out without problems.)

After removing the copy paper, stack the removed paper together with the new paper, fan it thoroughly, square it and reload.

DO NOT USE THE FOLLOWING TYPES OF PAPER

- Extremely smooth or glossy paper
- Coated paper
- Thermal paper
- Paper that is printed on one side
- Wrinkled paper, creased paper, etc.

1

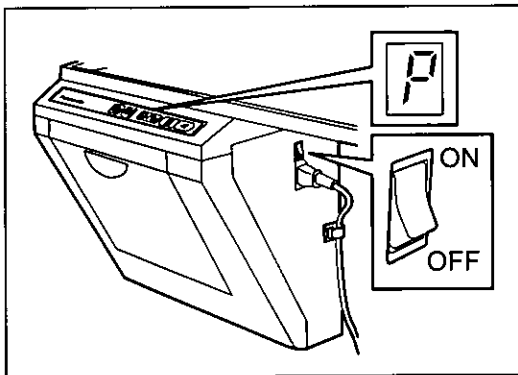

Set the power switch to on (I).

- "P" will flash on the Multi-Copy/Error Indicator when copy paper has run out.

2

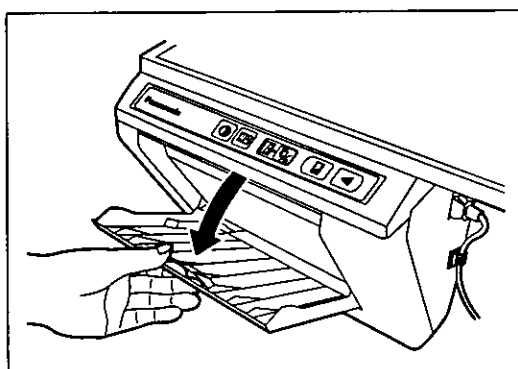

Pull the paper cover forward as shown in the left figure.

3

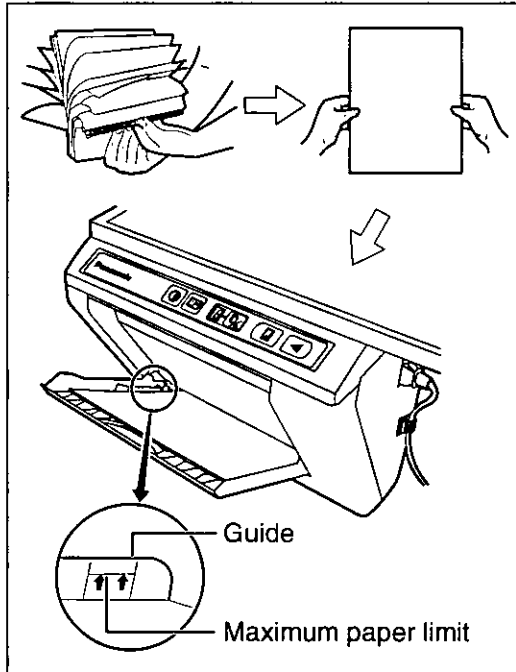

To prevent paper jams such as those caused by multiple sheets feeding at once, fan the paper thoroughly, square it, align it with the guide inside, and insert as far as it will go.

Notes

- Only use Letter size copying paper having a weight of 60 to 90 g/m^2 as the copy paper for this unit.
- Do not stack more copy paper in the unit than the maximum paper limit indicated by the guide (see figure to the left) as this may result in paper jams. (Note that the unit can hold about 40 sheets of paper having a weight of 80 g/m^2 .)

4

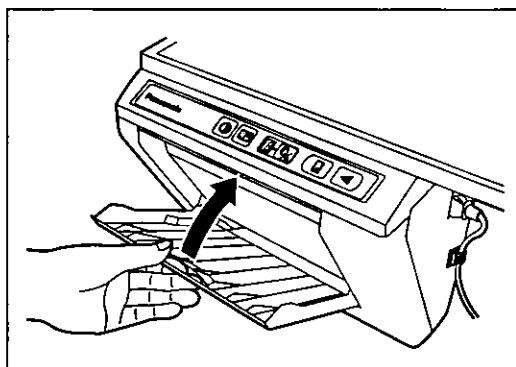

Close the paper cover until a click is heard.

Notes

- Close the paper cover, or the unit will not work properly.
- The paper cover should be closed to make copies properly. Confirm the both latches are locked.

Making Copies

This section describes how to copy text and illustrations drawn on the screen.

1

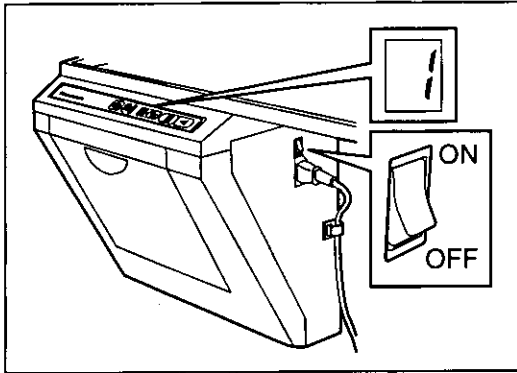

Set the power switch to on (I).

- " / " will light on the Multi-Copy/Error Indicator to indicate that the unit is ready to copy.

2

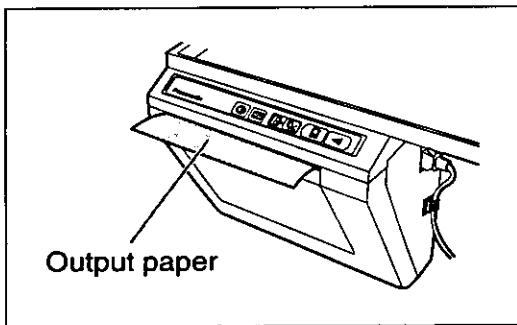







Press the Copy Key  .

- Text and illustrations on the screen will be copied and copies emerge from the output port.
- The output port can hold up to 10 sheets of copy paper. (Note that exceeding the output port's capacity may result in paper jams.)
- For details on making multiple copies, 2-screen copies and so on, see page 15.

Notes

- Do not use paper that has been copied on one side by this printer as copy paper in this unit or in any other copiers or printers as this may result in dirty rollers, degradation of printing quality, paper jams, and streaks and smudges on output paper.
- Do not write on the output paper from this unit with the printed side down. The ink on the printed side will be copied on the surface underneath the output paper.
- Text or images in shades of yellow will not copy.

■ Copy types and procedures

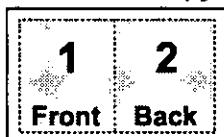
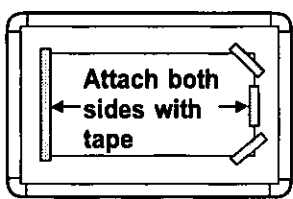
Copy Type	Procedure
Copying the front of the screen	Press  .
Copying the back of the screen	① Press  to move the screen to be copied to the front. ② Press  .
Making multiple copies (up to 9)	① Select the number of copies (1 to 9) by pressing  as necessary. ② Press  . • Press  to stop copying in mid-operation.
Making 2-screen copies • Copying the front and back of the screen on a single sheet of paper	Press  . <div style="text-align: center;"> 2-Screen Copy  </div>
Copying chart paper	Chart paper can be attached to the screen as shown in the figure and copied. (Be sure to take the chart off the screen soon after copying is finished.) <div style="text-align: center;">  </div> <ul style="list-style-type: none"> • Wrinkles, slackness or folds in the chart when attached to the screen will show up in copies as dark shadows. • Affix it to the screen with drafting tape made by 3M® or other similar tape with medium adhesive.

Operating Instructions

3M® is a registered trademark of 3M Corporation.

Replacing the Thermal Transfer Film

The unit is capable of producing about 15 more copies when the Contrast/Remaining Film Indicator begins to flash. The unit has run out of thermal transfer film and can no longer make copies when the Multi-Copy/Error Indicator flashes “r”. Separately available replacement film (UG-6001) may be purchased from the dealer where you purchased the unit. Thermal transfer film is replaced as follows.

Notes on Replacing Thermal Transfer Film

- Only use the designated product (UG-6001) from Panasonic as the replacement film. (Note that using another type of replacement film may result in degraded printing quality or damage to the unit.)
- Thermal transfer film is disposable. Dispose of used thermal transfer film as “burnable” or “non-recyclable” rubbish.
- A negative of the copied image will remain on the thermal transfer film. To protect the security of your information, we recommend cutting up the used thermal transfer film with scissors or shredder before disposing of it.

1

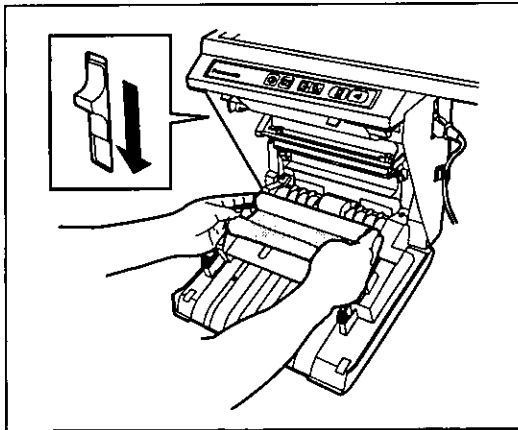

Push down the printer open lever to open the printer door, and remove the used film.

2

Refer to steps 3 and 4 in the section of “Installing the Thermal Transfer Film” on pages 10, 11.

Notes

- If “r” is still flashing after closing the printer door, make sure that the thermal transfer film has been installed properly and tightened.
- The printer door should be closed to make copies properly. Confirm both latches are locked.

Paper Jams

Remove paper jams by the following procedure when copy paper does not come out of the output port or when “J” flashes on the Multi-Copy/Error Indicator.

1

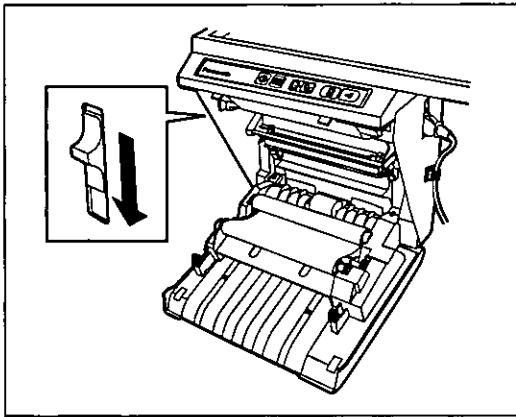

Push down the printer open lever to open the printer door.

2

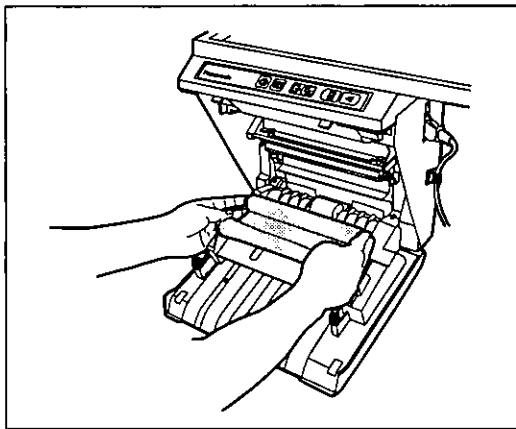

Remove the thermal transfer film with both hands.

3

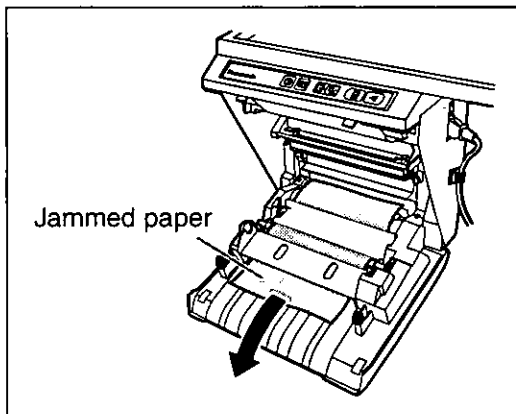

Remove the jammed paper.

4

Install the thermal transfer film.

- Refer to steps 3 and 4 in the section of “Installing the Thermal Transfer Film” on pages 10, 11.
- “J” flashing on the Multi-Copy/Error Indicator will go out.

Notes

- If “J” is still flashing after closing the printer door, make sure that the thermal transfer film has been installed properly and tightened.
- The printer door should be closed to make copies properly. Confirm both latches are locked.

If the flashing “J” does not go out after the foregoing procedure has been performed; this may indicate that the paper feeder is not functioning properly.

Reload the copy paper by following the steps given below.

1

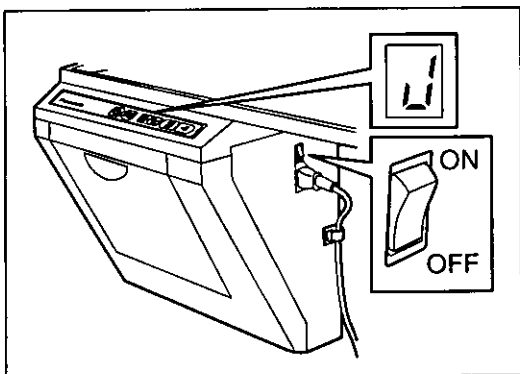

Turn the power off.

2

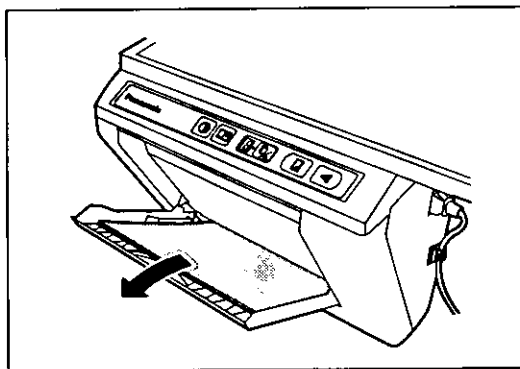

Open the paper cover and remove all the copy paper remaining inside the unit's paper cover.

Note

- The copy paper will slightly resist being removed, but may be pulled out without problems.

3

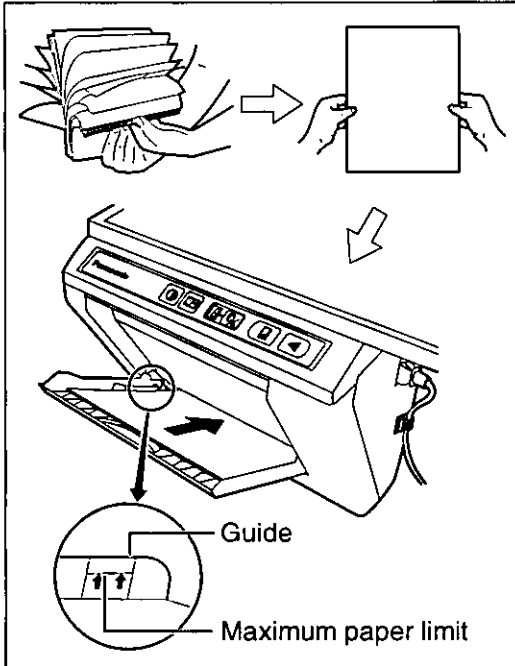

To prevent paper jams such as those caused by multiple sheets feeding at once, fan the paper thoroughly, square it, align it with the guide inside, and insert as far as it will go.

Note

- Do not stack more copy paper in the unit than the maximum paper limit indicated by the guide (see figure to the left) as this may result in paper jams. (Note that the unit can hold about 40 sheets of paper having a weight of 80 g/m².)

4

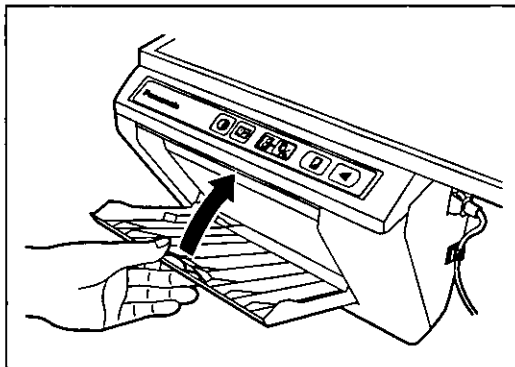

Close the paper cover until a click is heard.

Notes

- Close the paper cover, or the unit will not work properly.
- The paper cover should be closed to make copies properly. Confirm the both latches are locked.

5

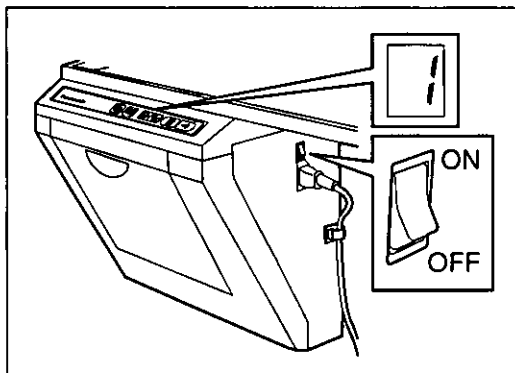

Turn the power on.

- “!” will light on the Multi-Copy/Error Indicator to indicate that the unit is ready to copy.

Screen Height Adjustment

The screen can be adjusted at 3 levels except for the lowest level. The lowest level of the board attachment frame is designed for installation of the screen, so the printer cannot be attached at this level. Adjust the level of the screen unit as follows.

Please lock the casters when you adjust the screen height. (Refer to page 5.)

1

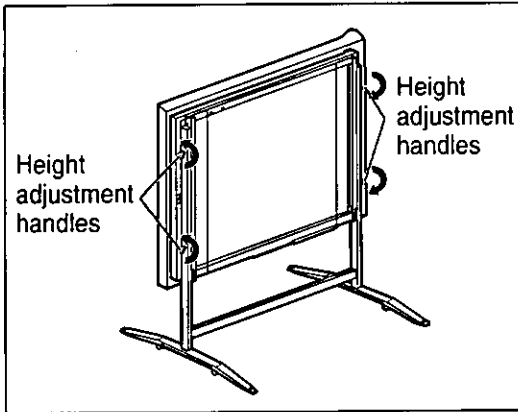

Loosen the height adjustment handles.

2

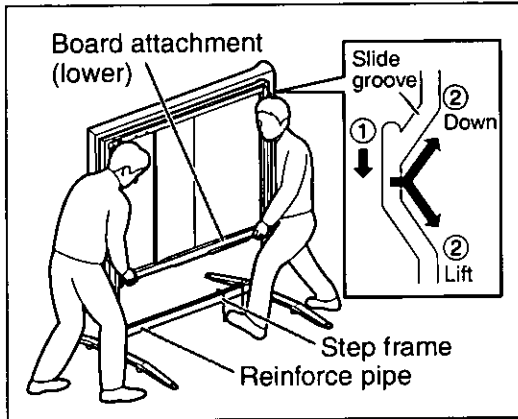

Hang the step frame on the reinforce pipe.

Lift the board attachment (lower) by stepping on the step frame.

Slide along the slide groove. ① ②

! The screen height must be adjusted by two people.

3

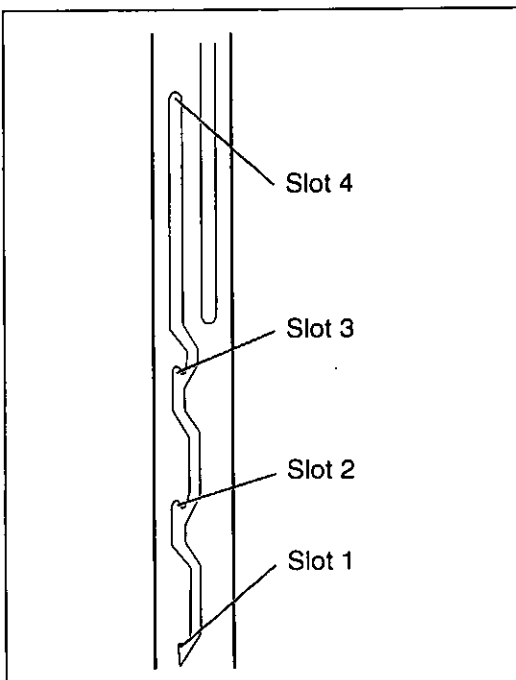

Hang the screen in the desired slots of the slide plates.

Slot	Adjustment	Screen Height
Slot 1	Available	2000 mm (6' 6 ³ / ₄ ")
Slot 2	Available	1875 mm (6' 1 ¹³ / ₁₆ ")
Slot 3	Available	1750 mm (5' 8 ⁷ / ₈ ")
Slot 4	Cannot be used	-

⊘ Do not use slot 4.
Slot 4 cannot be used for screen height adjustment.

! Confirm both sides of the screen are hung in the same height slots securely.

Screen Height Adjustment

4

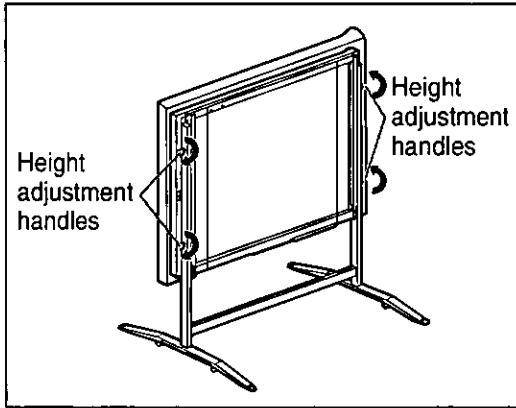

Tighten the height adjustment handles.



Be sure to tighten the height adjustment handles firmly after adjusting the level of the screen.

5

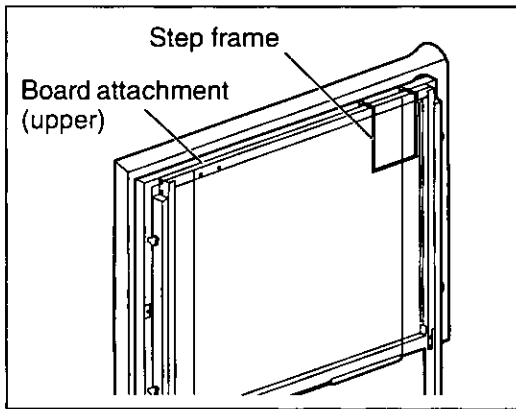

Store the step frame by hanging it on the board attachment (upper).

Computer Interfacing

- Panasonic Document Management System (hereafter Panasonic-DMS) uses the TWAIN driver to scan images drawn on the screen.
- The Panasonic-DMS has a capability of managing documents (image files).
- The printer driver allows the printer to print documents from your computer.

■ System requirements

Computer	IBM® PC/AT or compatible machine with a CD-ROM drive
CPU	Pentium® II or higher processor
Interface	USB 1.1 (B connector)
OS	Windows® 98 / Windows® Millennium Edition / Windows® 2000 / Windows® XP
Memory	64 MB or more (Windows 98/Me) 128 MB or more (Windows 2000) 256 MB or more (Windows XP)
HD	At least 40 MB free space (except saving space for image file)

- * The computer interfacing function of the UB-5315/UB-5815 is not available in Windows NT® 4.0.
- * If you connect the electronic board to a USB hub, it is not guaranteed to work.
- * Please note that if more than one Panasonic electronic boards are connected in a USB tree, only one of those electronic boards will perform the computer interfacing.

■ Contents of CD-ROM

The provided CD-ROM includes the following items.

- USB driver
- Printer driver
- Panasonic-DMS software
- TWAIN driver
- View Manuals
- Adobe® Acrobat® Reader

■ Connecting the unit to a computer

Power on the electronic board, and connect the unit and your computer with a USB cable.

Caution:

- * Use a shielded USB cable that is certified as logo by USB-IF.

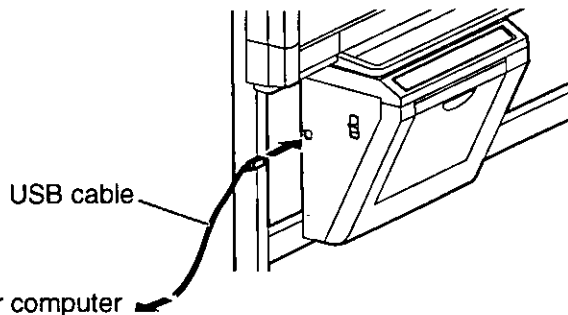

When you connect the unit for the first time, install the USB and Printer driver to your computer.

- Windows 98 → Page 23
- Windows Me → Page 24
- Windows 2000 → Page 26
- Windows XP → Page 27

- * When using Windows 98 or Windows Me, a floppy disk or CD-ROM for installing the operating system will also be necessary. (See page 25.)

■ Installing the driver and software

Installing the USB and Printer driver

Windows 98

- 1 Power on your computer and start Windows.
- 2 Power on the electronic board, and connect the unit and your computer with a USB cable.
- 3 When “**USB Composite Device**” is detected, click the [Next] button.
- 4 Click on the “**Search for the best driver for your device. (Recommended).**” check button and click the [Next] button.
- 5 Insert the CD-ROM into the CD-ROM drive. When the Setup window appears, click the (close button) to close it.
- 6 Select the “**Specify a location:**” only, then specify “**D (CD-ROM drive letter): \UB-5xxx\UsbDrv\Win98-Me**” in the text box, and click the [Next] button.
 - Do not select the CD-ROM drive. It may cause installing a wrong USB driver.

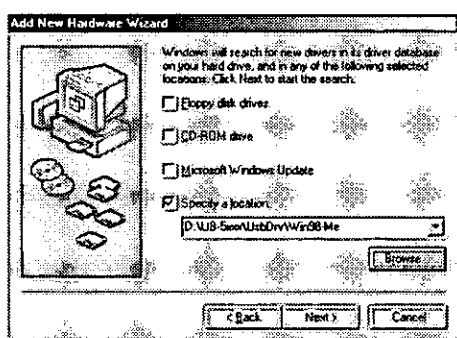

- 7 When the driver is found, click the [Next] button.
- 8 When the installation of “**USB Composite Device**” driver is completed, click the [Finish] button.

- 9 When “**Unknown Device**”^{*} is detected, click the [Next] button.
- 10 Click on the “**Search for the best driver for your device. (Recommended).**” check button and click the [Next] button.
- 11 Confirm that the “**Specify a location:**” is the same as step 6, click the [Next] button.
- 12 When the driver is found, click the [Next] button.
- 13 When the installation of “**USB Printing Support**” is completed, click the [Finish] button.
- 14 When “**Unknown Device**”^{**} is detected again, repeat steps 9 to 13 to install “**Panaboard-UB5 USB Device Driver**”.
- 15 When “**PanasonicPanaboard-UB5 USB Printer (Letter)**” is detected, click the [Next] button.
- 16 Click on the “**Search for the best driver for your device. (Recommended).**” check button and click the [Next] button.
- 17 Confirm that the “**Specify a location:**” is the same as step 6, click the [Next] button.
- 18 When the driver is found, click the [Next] button.
- 19 Follow the on-screen instructions when the “**Add Printer Wizard**” executes.
- 20 When the installation of “**Panaboard-UB5 USB Printer (Letter)**” driver is completed, click the [Finish] button.

* In the case of Windows 98 Second Edition, “USB Printing Support” is detected.

** In the case of Windows 98 Second Edition, “Panaboard-UB5 USB Device” is detected.

• A floppy disk or CD-ROM for installing the operating system will also be necessary. (See page 25.)

Windows Me

- 1 Power on your computer and start Windows.
- 2 Power on the electronic board, and connect the unit and your computer with a USB cable.
- 3 When “Panaboard-UB5 USB Device” is detected, click on the “Specify the location of the driver (Advanced)” check button and click the [Next] button.
- 4 Insert the CD-ROM into the CD-ROM drive. When the Setup window appears, click the (close button) to close it.
- 5 Select the “Specify a location:” only, then specify “D (CD-ROM drive letter): \UB-5xxx\UsbDrv\Win98-Me” in the text box, and click the [Next] button.
 - Do not select the CD-ROM drive. It may cause installing a wrong USB driver.

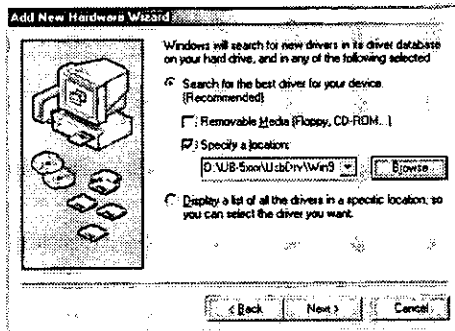

- 6 When the driver is found, click the [Next] button.
- 7 When the installation of “Panaboard-UB5 USB Device Driver” is completed, click the [Finish] button.
- 8 When “Panaboard-UB5 USB Printer” is detected, click on the “Specify the location of the driver (Advanced)” check button and click the [Next] button.

- 9 Confirm that the “Specify a location:” is the same as step 5, click the [Next] button.
- 10 When the driver is found, click the [Next] button.
- 11 When the installation of “USB Printing Support” is completed, click the [Finish] button.
- 12 When “PanasonicPanaboard-UB5 USB Printer (Letter)” is detected, click on the “Specify the location of the driver (Advanced)” check button and click the [Next] button.
- 13 Confirm that the “Specify a location:” is the same as step 5, click the [Next] button.
- 14 When the driver is found, click the [Next] button.
- 15 Follow the on-screen instructions when the “Add Printer Wizard” executes.
- 16 When the installation of “Panaboard-UB5 USB Printer (Letter)” driver is completed, click the [Finish] button.
 - A floppy disk or CD-ROM for installing the operating system will also be necessary. (See page 25.)

Note

Special Note for Windows 98/Me

If your computer had Windows 98/Me pre-installed and the original Windows 98/Me CD-ROM or diskettes were not included. In this situation, please try to locate the necessary files by following the methods described below or refer to your computer's User's Guide for more details.

Method-1:

Specify the Windows 98/Me backup file location in the hard disk of your computer.

Generally, the Windows 98/Me backup files are located in the "WINDOWS\OPTIONS\CABS" folder. Type "C:\WINDOWS\OPTIONS\CABS" in the [Copy files from:] box on the "Copying Files..." dialog box, where "C:" is your Windows 98/Me boot drive and then click the [OK] button. If the necessary files are found, the installation will proceed.

Otherwise, click the [Details...] button, a dialog box appears as shown below including the cabinet file name (*.CAB listed under the Description File) that contains the necessary file.

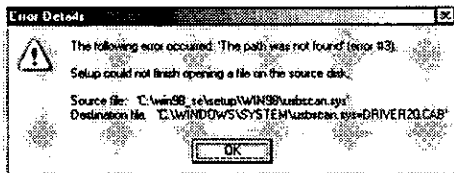

In this example, the cabinet file name is "DRIVER20.CAB". (Note that the cabinet file name may vary depending on your computer.)

To search for the file in your computer

- 1 Click the [Start] button on the Task Bar and then click on [Find]–[Files or Folders...] (Windows 98) or [Search]–[For Files or Folders...] (Windows Me).
- 2 A dialog box appears prompting for a file name to be searched, type "DRIVER*.CAB" in the [Named:] (Windows 98) or [Search for files or folders named:] (Windows Me) box, choose "C:" in the [Look in:] box and check the box for [Include subfolders] (only for Windows 98).
- 3 Click the [Find Now] (Windows 98) or [Search Now] (Windows Me) button. When the cabinet file is found, make a note of the folder name where the file is located.
- 4 Return to the "Copying Files..." dialog box and type the folder name in the [Copy files from:] box. For example, type "C:\WINDOWS\OPTIONS\CABS". Then click the [OK] button.

Method-2:

Create the Windows 98/Me backup diskettes and then specify the diskettes.

Depending on the computer, there is usually a tool from the manufacturer to create the Windows 98/Me backup diskettes in a Windows 98/Me pre-installed system. Please refer to your PC's User's Guide for more details on this tool.

Create the Window 98/Me backup diskettes by using this tool, and then install the USB and Printer driver by following the procedures from Step 1.

Windows 2000

- 1 Power on your computer and start Windows.
 - Log on as an administrator.
- 2 Power on the electronic board, and connect the unit and your computer with a USB cable.
- 3 When “Welcome to the Found New Hardware Wizard” dialog box appears, click the [Next] button.
- 4 When “Panaboard-UB5 USB Device” is detected, click on the “Search for a suitable driver for my device (Recommended)” check button and click the [Next] button.
- 5 Insert the CD-ROM into the CD-ROM drive. When the Setup window appears, click the (close button) to close it.
- 6 Select the “Specify a location” only, then click the [Next] button.
 - Do not select the CD-ROM drive. It may cause installing a wrong USB driver.

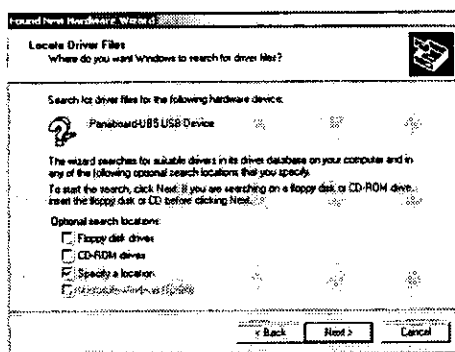

- 7 Specify “E (CD-ROM drive letter): \UB-5xxx\UsbDrv\Win2K-XP” in the text box, and click the [OK] button.
- 8 When the driver is found, click the [Next] button.

- 9 Although “Digital Signature Not Found” dialog box appears, click the [Yes] button to continue the installation.
- 10 When the installation of “Panaboard-UB5 USB Device Driver” is completed, click the [Finish] button.
- 11 When “Welcome to the Found New Hardware Wizard” dialog box appears again, click the [Next] button.
- 12 When “Unknown” is detected, click on the “Search for a suitable driver for my device (recommended)” check button and click the [Next] button.
- 13 Select the “Specify a location” only, then click the [Next] button.
 - Do not select the CD-ROM drive. It may cause installing a wrong USB driver.
- 14 Confirm that the “Copy manufacturer’s files from:” is the same as step 7, click the [OK] button.
- 15 When the driver is found, click the [Next] button.
- 16 Although “Digital Signature Not Found” dialog box appears, click the [Yes] button to continue the installation.
- 17 When the installation of “Panaboard-UB5 USB Printer (Letter)” driver is completed, click the [Finish] button.

- The standard printer name is “Panaboard-UB5 USB Printer (Letter)”.

Windows XP

- 1** Power on your computer and start Windows.
 - Log on as an administrator.
- 2** Power on the electronic board, and connect the unit and your computer with a USB cable.
- 3** When “Panaboard-UB5 USB Device” is detected, click on the “Install from a list or specific location (Advanced)” check button and click the [Next] button.
- 4** Insert the CD-ROM into the CD-ROM drive. When the Setup window appears, click the (close button) to close it.
- 5** Select the “Include this location in the search:” only, then specify “E (CD-ROM drive letter): \UB-5xxx\UsbDrv\Win2K-XP” in the text box, and click the [Next] button.
 - Do not select the CD-ROM drive. It may cause installing a wrong USB driver.

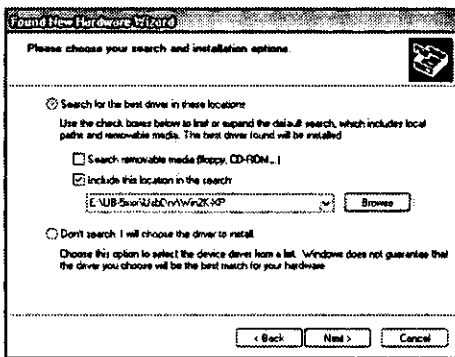

- 6** Although the “Hardware Installation” dialog box appears, click the [Continue Anyway] button to continue the installation.
- 7** When the installation of “Panaboard-UB5 USB Device Driver” is completed, click the [Finish] button.

- 8** When “Panasonic Panaboard-UB5 USB Printer (Letter)” is detected, click on the “Install from a list or specific location (Advanced)” check button and click the [Next] button.
- 9** Confirm that the “Include this location in the search:” is the same as step 5, click the [Next] button.
- 10** Although the “Hardware Installation” dialog box appears, click the [Continue Anyway] button to continue the installation.
- 11** When the installation of “Panaboard-UB5 USB Printer (Letter)” driver is completed, click the [Finish] button.

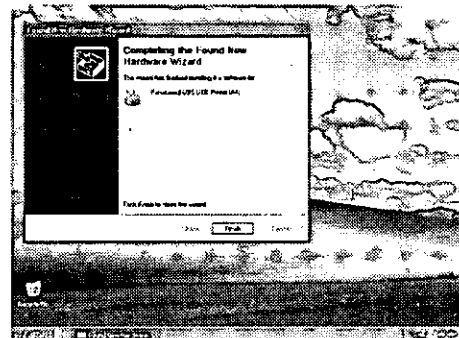

- The standard printer name is “Panaboard-UB5 USB Printer (Letter)”.

Computer Interfacing

Installing Panasonic-DMS software and TWAIN driver

When an old version of Panasonic-DMS is already installed, remove it and install the new version of the software in the same folder.

- 1 Power on your computer and start Windows.
 - Log on as an administrator for Windows 2000 or Windows XP.
- 2 Insert the CD-ROM into the CD-ROM drive. The Setup window will appear automatically.
 - Depending on the operating system or the settings that you are using, the Setup window may not appear automatically. In such a case, execute "menu.exe" in the CD-ROM from the Explorer.
- 3 Click on the desired language.
 - Even when French, Spanish or Italian is chosen, the TWAIN driver of the English version is installed.

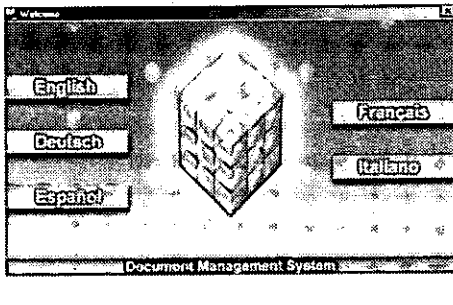

- 4 When "Welcome" dialog box appear, click the [Next] button.
- 5 Click the [Panasonic-DMS] button.
 - Click [Adobe Acrobat Reader 5.0] to install the Acrobat Reader. To read the operating instructions, the Acrobat Reader must be installed in your computer.

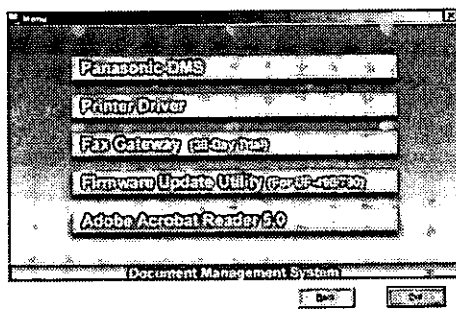

- 6 Click the [Install Panasonic-DMS Software] button.

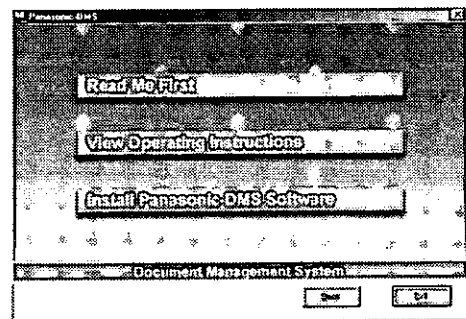

- 7 Enter the installation destination and click the [Next] button.
- 8 Enter the data folder and click the [Next] button.
- 9 Select "UB-5xxx" and click the [>>] button. Select and add other products that use Panasonic-DMS software. Then, click the [Next] button.

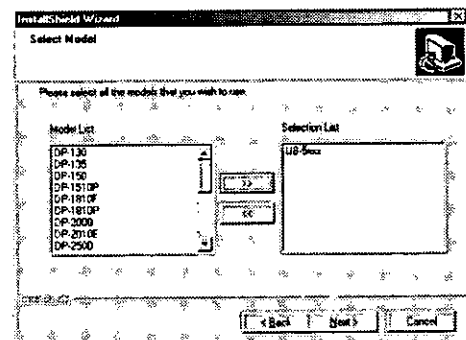

- 10 When "Select Setup Type" dialog box appear, click the [Typical] button.
- 11 Enter the program folder name and click the [Next] button. Then follow the instruction on the screen.
- 12 Follow the on-screen instructions when other messages are displayed.
- 13 When the setup process is completed and a message is displayed prompting you to restart your computer, restart Windows.

- Log on as an administrator for Windows 2000 or Windows XP.
- About the Document Manager, refer to the Document Manager System operating instructions in the CD-ROM.

■ **Removing the driver and software**

Removing Panasonic-DMS software and TWAIN driver

If you need to remove the Panasonic-DMS software and TWAIN driver, perform the following steps.

- 1 Power on your computer and start Windows.
 - Log on as an administrator for Windows 2000 or Windows XP.
- 2 Click **[Start]**, move the pointer to **[Programs]–[Panasonic]–[Panasonic Document Management System]–[Uninstall]**.
(For Windows XP, **[All Programs]** instead of **[Programs]**.)
- 3 Select the **[Remove]** check button and click the **[Next]** button.
- 4 Follow the instructions on the screen.
- 5 After uninstalling, restart your computer.

■ **Scanning**

You can scan images on the screen to your computer by operating Panasonic-DMS.

- 1 Click **[Start]**, move the pointer to **[Programs]–[Panasonic]–[Panasonic Document Management System]–[Document Manager]**.
(For Windows XP, **[All Programs]** instead of **[Programs]**.)
 - The Panasonic-DMS software runs.
- 2 Click the **[File]** menu, then click **[Select Source...]**.
- 3 Select **[Panaboard-UB5 USB TWAIN Driver]** and click the **[Select]** button.

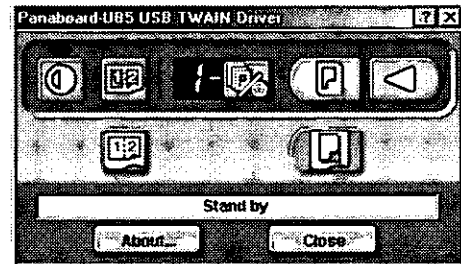

- 4 Click the **[File]** menu, then click **[Acquire Image...]**, or click the  (scanner) icon on the Toolbar.

- The Panaboard Operation Panel will appear.



Note

- When the Panaboard Operation Panel is not displayed, check the USB cable connection or the condition of the electronic board.

- 5 Click the  (Scan) button or the  (2-Screen Scan) button.

- Scanning starts and the scanned image will be displayed on the screen of the computer. It is also possible to start scanning using the Copy Key or 2-Screen Copy Key on the electronic board.

- 6 Click **[Close]** on the Panaboard Operation Panel to finish scanning.

- About the Document Manager, refer to the Document Manager System operating instructions in the CD-ROM.

Note

- Dragging the Panaboard Operation Panel or activating other software programs may cause scanning troubles.









Operating Instructions

Computer Interfacing

■ Panaboard Operation Panel

It is possible to perform the same operations as with the electronic board control panel (page 9) from the following Panaboard Operation buttons.

Note: While the Panaboard Operation Panel is displayed, the Copy Key and 2-Screen Copy Key on the electronic board control panel are used for scanning images into the computer.

Panel	Name	Description
	① Contrast/Remaining Film Indicator	This lamp indicator notifies the user when the time to replace the thermal transfer film is approaching (estimated) and of the printing contrast used during scanning or copying. Indicator off: Normal scanning or copying contrast Indicator on: Darker than normal scanning or copying contrast Indicator flashing*: Almost time to replace the thermal transfer film (Note that only about 15 more sheets may be copied when this indicator starts flashing.) Replacement film (UG-6001) is separately available from the dealer where you purchased your unit. * The flashing indicator will go out after the power is turned off and the printer has been opened and closed. (When copying is performed, this indicator will begin flashing again.)
	② Contrast Button	Each time this button is pressed, the unit will alternate between normal and dark contrast modes (Normal/Dark).
	③ 2-Screen Scan Button	This button scans the front and back of the screen on a single page.
	④ Multi-Copy/Error Indicator	This indicator displays the number of copies to be made. The display changes each time the Multi-Copy/Stop Button is pressed. Example: 1 → 2 → ... → 9 → 1 → ... When an error occurs, a flashing symbol will appear in this display to indicate the error status. (See page 35.)
	⑤ Multi-Copy/Stop Button	When making multiple copies, press this button until the desired number of copies is displayed on the Multi-Copy/Error Indicator. This button can also be pressed while multiple copies are being made to stop the copying process. * During scanning, the setting 1 to 9 for the number of copies is ignored.
	⑥ Scan Button	This button scans the screen.
	⑦ Advance Button	This button advances the screen from right to left.
	⑧ 2-Screen Copy Button	This button causes the front and back of the screen to be copied on a single sheet of paper.
	⑨ Copy Button	This button causes the screen to be copied.

Status Box

The status box displays the status of the TWAIN driver and the electronic board.

- Stand by: The electronic board is stand by. Both of the Panaboard Operation Panel and the electronic board control panel are operational.
- Rotating: The electronic board is rotating the screen.
- Copying: The electronic board is copying the screen.
- Scanning: The electronic board is now scanning the images on the screen.
- Converting: Indicates that the image data is being converted so that the computer will be able to display the scanned data.
- Busy: The electronic board is processing jobs.
- Error: An error has occurred with the electronic board.

About Button

Click to display information about the TWAIN driver.

Close Button

Click to close the Panaboard Operation Panel.

■ Printing

To print documents from the computer to the printer, select the Print menu of the application software and select the printer name set when installing.

The standard printer name is "Panaboard-UB5 USB Printer (Letter)".

Notes

- The Multi-Copy/Error Indicator flashes when printing.
After printing, all the panel keys are disabled until the Multi-Copy/Error Indicator lights.
- When the operation panel of the TWAIN driver is displayed, printing is not available.
- You cannot stop printing after printing starts. Do not attempt to stop printing.
- Do not turn off the power of the electronic board or unplug the USB cable before printing finishes. It may cause the computer operation to become unstable.
- A maximum 9 copies are available.
- The output port can hold up to 10 sheets of copied paper. (Note that exceeding the output port's capacity may result in paper jams.)
- The Contrast Key is not effective for adjusting the contrast of print.
- When printing almost black pages continuously uniform color density and light line streaks may appear. In such a case, try again after waiting a while.
- When the unit falls in abnormal condition during printing, printing jobs (jobs in the spooler) may be lost. In such a case, print again.

Daily Care and Maintenance

Always turn off the power switch and unplug the power plug when cleaning outside and inside the unit.

■ Cleaning the screen and the unit

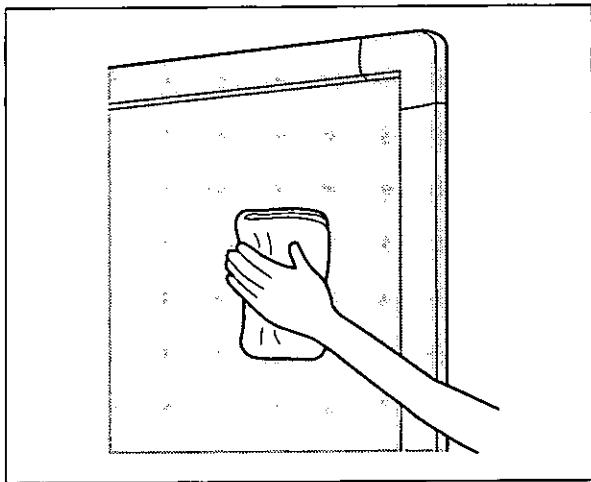

Gently wipe the screen film and unit with a water-dampened cloth that has been thoroughly wrung.

- Use a kitchen cleaner diluted with water for hard-to-clean stains.
- If you accidentally write on the board with an oil-based marker, wipe with a small amount of ethyl alcohol.

Notes

- Use a neutral kitchen cleaner diluted with water for hard-to-clean stains. (If you accidentally write on the screen with an oil-based marker, wipe with a small amount of ethyl alcohol.)
- Do not use thinner, benzine or cleaners containing abrasives as this may result in discoloration.
- Do not wipe the screen film with a dry cloth as this may generate a static charge.

■ Caring for the eraser

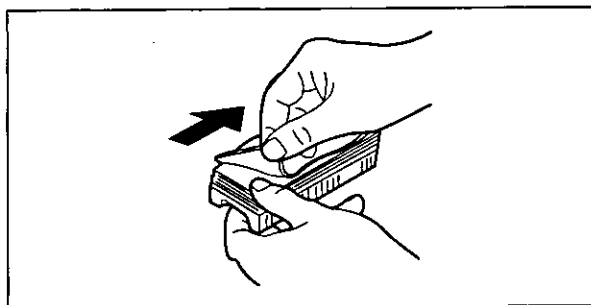

When the erasing surface of the eraser becomes dirty, hold down the sheet under the top sheet with your finger and peel off the dirty sheet by pulling in the direction of the arrow.

Note

- When the eraser becomes thin, make sure that the corners of the eraser do not strike the screen during erasing as this may damage the screen.

■ Cleaning the printer head, platen roller and pick-up roller

If black streaks appear on the copy, clean the printer head and the platen roller.

If paper jams occur frequently, clean the pick-up roller.

1

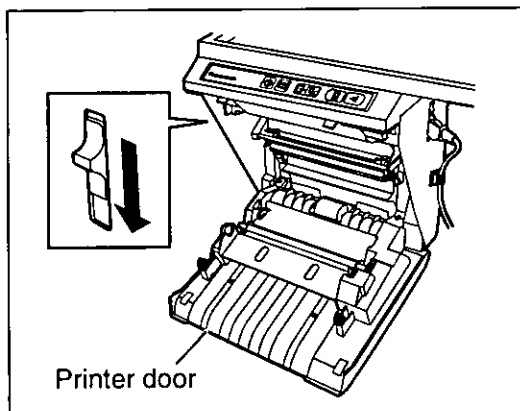

Push down the printer open lever and open the printer door.

2

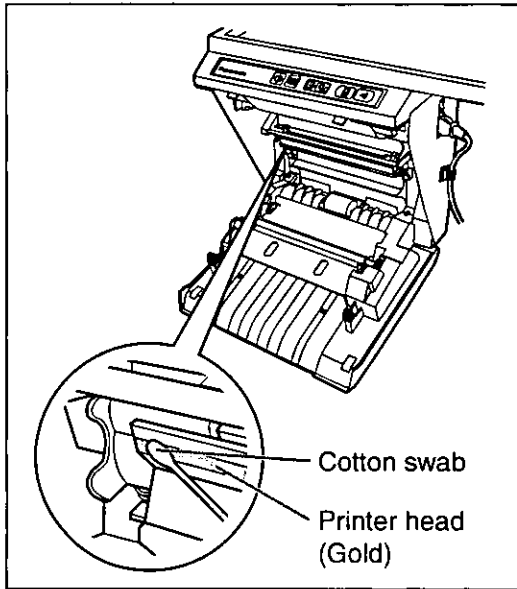

Clean the Printer Head

Dampen the tip of a cotton swab in ethyl alcohol and gently wipe the printer head.

Note

- Never touch the printer head or the surrounding area with your hands as this may disable copying.

3

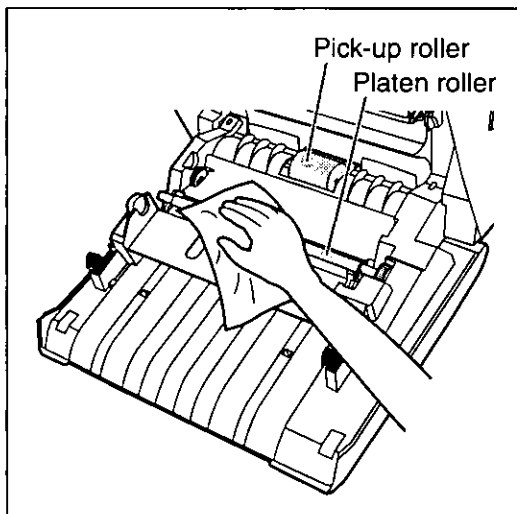

Clean the Platen Roller and the Pick-up Roller

Remove the thermal transfer film with both hands and carefully wipe any dirt or stains off the platen roller and pick-up roller.

- For details on removing the thermal transfer film, see page 16.
- Dampen a soft cloth with neutral kitchen cleaner diluted in water, wring the cloth thoroughly, and wipe the entire surface of the rollers while rotating them. If this does not remove all dirt, wipe with a cloth dampened with ethyl alcohol.

4

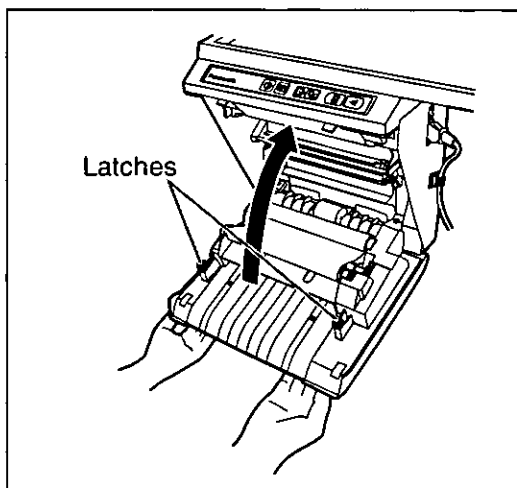

Install the thermal transfer film in its original position and close the printer door.

- For details on installing the thermal transfer film, see pages 10, 11.
- Close the printer door firmly until a click is heard.

Note

- If "r" is displayed on the Multi-Copy/Error Indicator when the power is turned on, this indicates that the thermal transfer film has not been installed properly or that there is slack in the thermal transfer film. Check the condition of the thermal transfer film and for slack in the thermal transfer film.

Troubleshooting

Treat problems according to the information given in the table below. If problems still persist, call your dealer for service.

Symptom	Care and Remedy	See Page
Power switch is on but the indicator is off.	Check that the power plug is securely plugged in. (If the indicator still does not light, turn the power off and on again.)	–
Copied copy paper will not come out.	The unit is out of copy paper or thermal transfer film. (The Error Indicator flashes “P” or “r”.) → Insert copy paper or replace the thermal transfer film.	12 16
	The printer door is open. (The Error Indicator flashes “d”.) → Close the printer door firmly until a click is heard.	11
	Paper is jammed in the printer. (The Error Indicator flashes “J”.) → Open the printer door and remove the jammed paper.	17
	The platen roller and pick-up roller are dirty. → Open the printer door and wipe the platen roller and the pick-up roller to clean them.	32
Nothing is printed on the paper or copies are faint or blurred.	The writing on the screen is too thin or light. → Make thicker, darker lines or change to a new marker.	–
	The printer door is slightly open. → Close the printer door firmly until a click is heard.	11
Black streaks or blank (unprinted) spots appear on the copy (copy paper is dirty).	The printer head or platen roller is dirty. → Open the printer door and clean any dirt off the printer head and platen roller.	32
	The thermal transfer film is wrinkled because it was set in place without removing excess slack. → Rewind the used portion of the thermal transfer film to remove the excess slack, then reattach it.	10
A black or white horizontal line appears, or the page prints in black or blank.	The unit is in strong sunlight or strong lighting. → Change the direction of the screen or block the light.	–
The USB driver or printer driver does not work properly immediately after the installation of the software.	The Panaboard has not been registered in [Control Panel]–[Scanners and Cameras] and [Printers]. → Run “UB-5xxx\Uninstall\UB5Uninst.exe” in the CD-ROM to uninstall the drivers from the computer. Then, install the drivers.	23–27
The computer does not recognize the electronic board.	Check that the electronic board is in the condition that enables operation or that the USB cable is connected properly.	–
	The electronic board is connected via a USB hub. → Do not connect via a USB hub.	–
The screen does not advance when the Copy or Advance Key is pressed.	Static electricity was generated when the screen film was wiped. → Turn off the power and slowly move the screen by hand.	–
Contrast/Remaining Film Indicator flashes.	The time to replace the thermal transfer film is approaching. (Only about 15 more sheets may be copied.) → Prepare a new replacement film (UG-6001).	16

■ Meanings of error codes

The following table describes the meaning of each of the symbols which may flash in the Multi-Copy/Error Indicator.

Indication	Cause	Remedy	See Page
E (Error)	Data transfer error	Connect the USB cable securely.	22
S (Screen)	The screen will not move.	Remove any chart paper attached to the screen and slowly move the screen by hand.	-
d (door)	The printer door is not closed securely.	Close the printer door securely.	11
J (Jam)	Paper jam	Open the printer door and remove the jammed paper.	17
r (ribbon)	The thermal transfer film is slack, has run out or is not installed.	Remove the slack from the thermal transfer film, replace or install the thermal transfer film.	10 16
P (Paper)	Out of paper	Load copy paper.	12
F (Scanner Failure)	The scanner or screen is in strong sunlight or strong lighting.	Change the direction of the screen or block the light.	-

If other indications such as “*n*” appear, call your dealer.

Specifications

	Model No.	UB-5315	UB-5815	
General	Power supply	AC 100 - 120 V, 50/60 Hz		
	Power consumption (Operational)	1.4 A		
	External dimensions (Height × Width × Depth, without stand)	1334 mm × 1372 mm × 212 mm (4' 4 ¹ / ₂ " × 4' 6" × 8 ¹¹ / ₃₂ ")	1334 mm × 1735 mm × 212 mm (4' 4 ¹ / ₂ " × 5' 8 ⁵ / ₁₆ " × 8 ¹¹ / ₃₂ ")	
	Mass (without stand/ with board attachment)	25 kg (55.1 lbs.)	27 kg (59.5 lbs.)	
	Ambient operating conditions	Temperature: 10–35° C (50–95°F) Humidity: 30–80% RH		
	Writing implements	Dry erase felt-tipped markers (black, red, and blue)		
Input Block	Panel dimensions (Height × Width)	900 mm × 1262 mm (2' 11 ⁷ / ₁₆ " × 4' 1 ¹¹ / ₁₆ ")	900 mm × 1625 mm (2' 11 ⁷ / ₁₆ " × 5' 3 ³¹ / ₃₂ ")	
	Panel surfaces	2		
	Panel advance system	Endless scroll type		
	Copying area (Height × Width)	850 mm × 1250 mm (2' 9 ¹⁵ / ₃₂ " × 4' 1 ⁷ / ₃₂ ")	850 mm × 1613 mm (2' 9 ¹⁵ / ₃₂ " × 5' 3 ¹ / ₂ ")	
	Scanning system	Image sensors		
Output Block	Printing system	Fusion thermal transfer type		
	Copy paper	Standard or recycled paper		
	Copy paper size	Letter [216 mm × 279.4 mm (8 ¹ / ₂ " × 11")]		
	Copy density	8 dots/mm (203 dots/inch)		
	Copy color	Black		
	Contrast adjustment	Two levels: Normal/Dark		
	2-screen compressed copying	Yes		
	Time required for copying	15 s/sheet		
	Continuous copies	1 to 9 sheets		
	Paper empty indication	Yes		

■ Option and Separately available

Option	Stand: UE-608005
Separately Available	Replacement film: UG-6001 (Set of 2 rolls [50 m (164 ft.)])
	Markers: KX-B031 (set of 10 black markers), KX-B032 (set of 10 red markers), KX-B033 (set of 10 blue markers)
	Erasers: KX-B042 (set of 6 erasers)
	Marker and eraser set: KX-B035 (contains one black, one red, and one blue markers and one eraser)

Installation Manual

(for qualified service personnel)

Table of Contents

	page
Assembling the Electronic Board	38
● Accessories for assembling	38
● Assembly	39
Electronic Board Operations Check	46
Repacking	47
Assembling the Optional Stand (UE-608005)	48
● Accessories	48
● Assembly	49
Wall-mounting	52
● Wall-mounting fixture	52
● Wall-mounting procedure	53
● Attaching the wall-mounting fixtures	54

Before installing this set, please read this manual completely.

CLASS 1 LED PRODUCT

WARNING



DO NOT INSTALL THIS OPTION EXCEPT QUALIFIED SERVICE PERSONNEL.

CAUTION











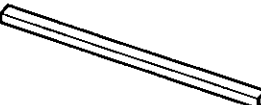

SAFETY CHECK MUST BE DONE BY QUALIFIED SERVICE PERSONNEL AFTER INSTALLING THIS OPTION.

Installation Manual

Assembling the Electronic Board

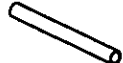
■ Accessories for assembling

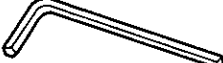
The package includes the parts for setting up the electronic board shown below. Make sure that all of these parts are included in the package before proceeding.

Part Name	Illustration/Quantity					Remarks
	UB-5315	UB-5815	Q'ty			
Board attachment (upper) [*Wall-mounting fixture (upper)]					1	
Board attachment (lower) [*Wall-mounting fixture (lower)]					1	
Cover (upper)					1	
Cover (lower)					1	
Screws and spacers	6 (Long)  For screen	6 (Short)  For printer and screen	1*  For cover	2**  For screen	6  For screen	6 Screen Page 41, Step 11 Printer Page 43, Step 17 Cover (lower) Page 45, Step 22 * 1 screw for UB-5315 ** 2 screws for UB-5815
Wrench					1	
Power cord					1	
Wall-mounting template					1	Use the wall-mounting template 1 and 2 by pasting them together.

* These names [Wall-mounting fixture (upper)/Wall-mounting fixture (lower)] are used for installing on the wall.

■ Assembly

1 Assemble the optional stand or wall-mounting fixture.

■ If you are using a stand, refer to page 48.

■ If you are using a wall-mounting fixture, refer to page 52.

2 Remove the electronic board from the shipping box.

Remove the joints, then remove the electronic board from the shipping box.

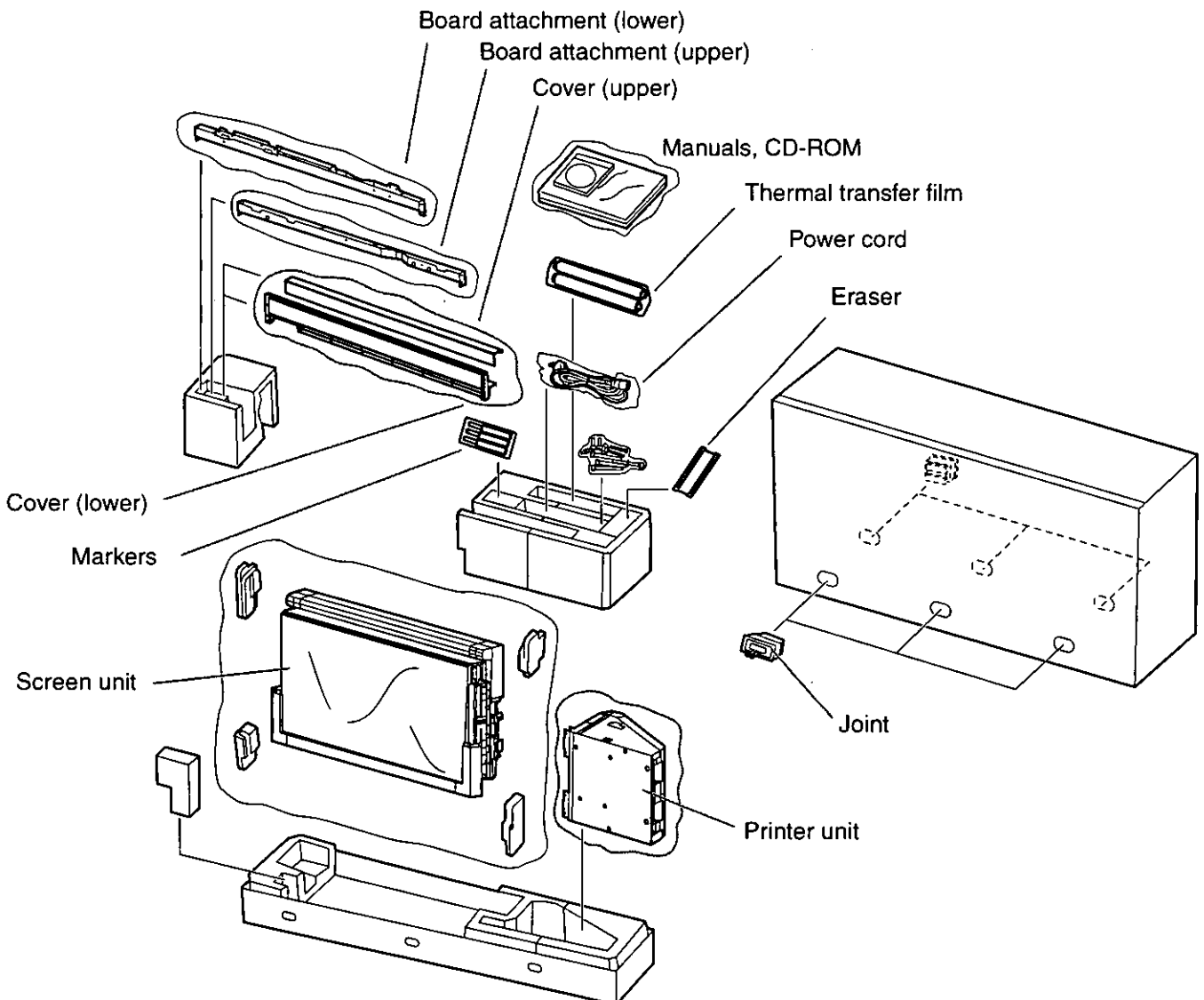

Caution

- When removing the screen unit, grasp the side cover on either side of screen. Do not grasp the screen film surface, as this may scratch it.
- The shipping box, cushioning material, and other packing material will be necessary if you ever need to repackage the electronic board, so do not throw them away.

Assembling the Electronic Board

3 Collapse the carton box.

Remove the tape on the unopened side of the carton box, then collapse the box.

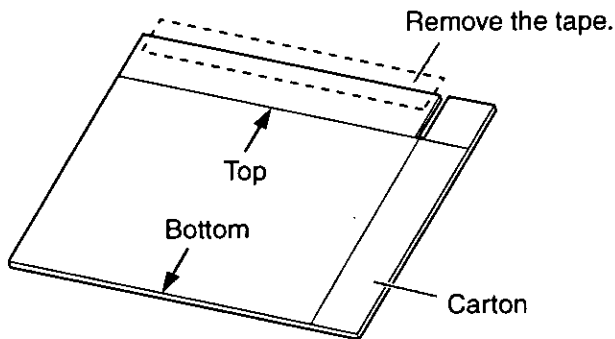

4 Remove the protective plastic bags.

Remove the protective plastic bag from the screen unit and printer unit. Set those units on the top of collapsed shipping box and remove the cushions.

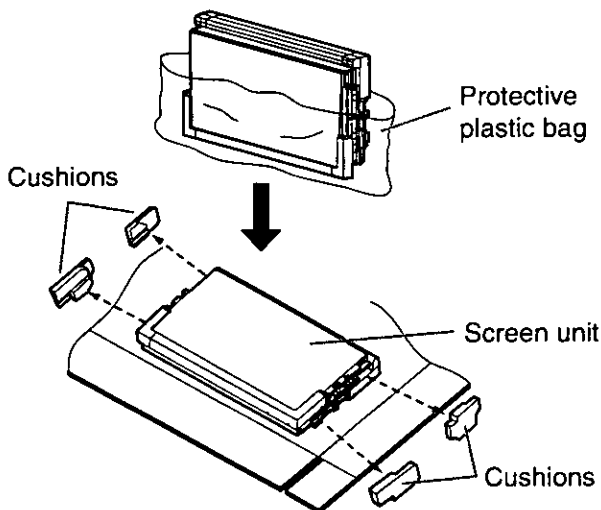

Caution

- Touch the screen film surface gently to avoid any damage.

5 Attach the screen unit to the optional stand or wall mounting fixture.

- If you are using the stand, refer to page 48.
- If you are using the wall mounting fixture, refer to page 52.

6 Hang the screen unit to the board attachment (upper).

Hold the side covers of the screen unit and hang two hooks of the screen unit on the left side of the board attachment (upper).

Shift the screen unit to the left until it stops. Confirm the left hook is inserted into the groove of the board attachment (upper).

- When hanging the screen unit, set the board attachment frame at the lowest level.
- Be careful not to catch the screen film on the board attachment frame.

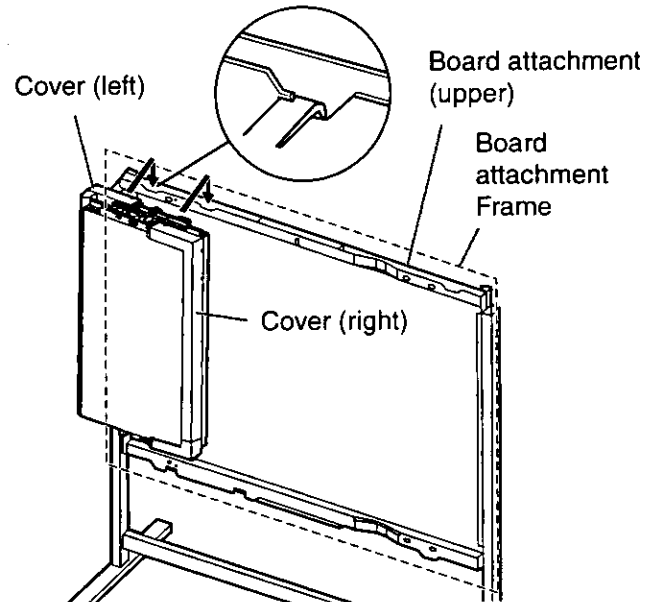

7 Remove the shipping screws.

Remove the upper and lower shipping screws on the folded screen.

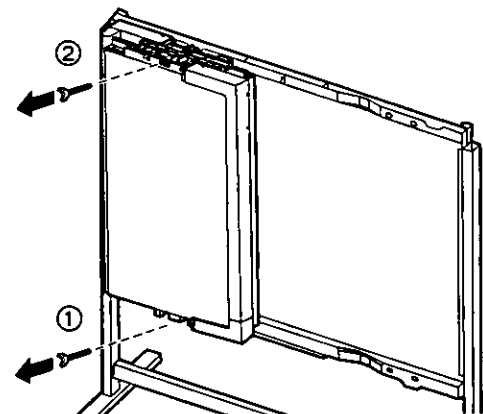

Caution

- Remove the lower shipping screw first.

8 Extend the screen unit.

Open the center and right panels of the screen unit as shown below and remove the cushion.

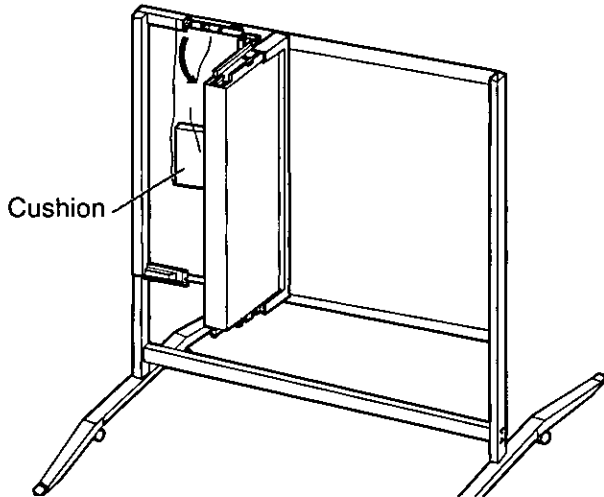

Caution

- Touch the screen film surface gently when opening the screen unit.

9 Unlock the hook.

Unlock the hook connected to the center and right panels. Extend the screen unit and remove the cushion behind the screen.

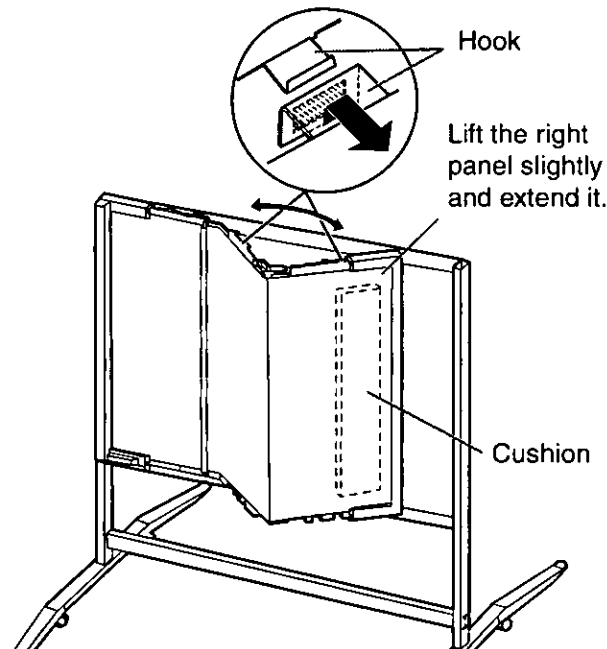

Caution

- Touch the screen film surface gently when opening the screen unit.

10 Extend the screen unit.

Hang the right hook of the screen unit on the board attachment (upper).

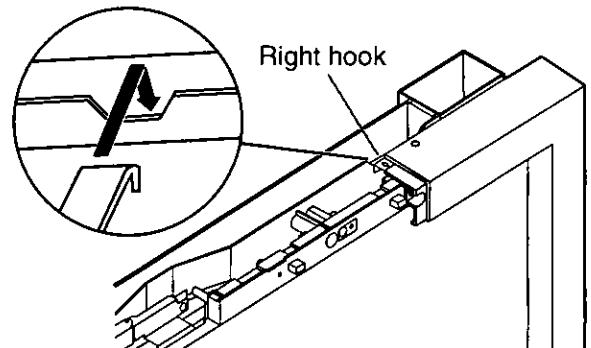

Caution

- Touch the screen film surface gently when opening the screen unit.

11 Fix the screen unit.

Fix the left, center and right panels with the screws and spacers supplied. To tighten the screws, use the supplied wrench.

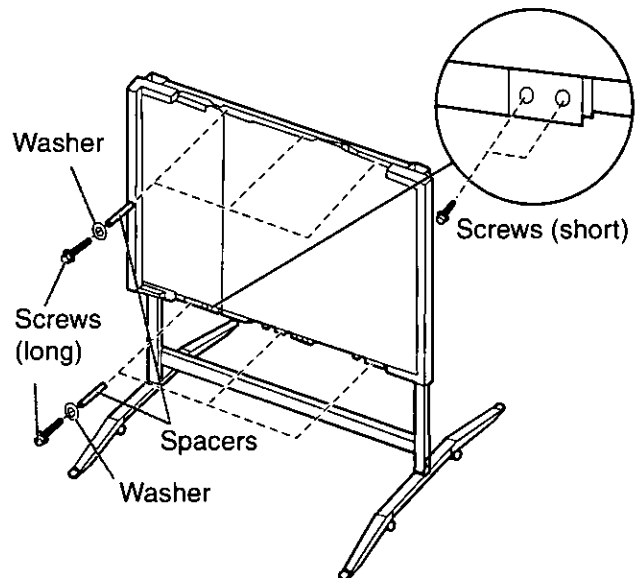

Assembling the Electronic Board

■ Adjusting the level of the screen unit (Step 12–15: only for use of the optional stand)

At the lowest level of the board attachment frame, the printer cannot be installed. Raise the level of the screen unit as follows.

- Please lock the casters when you adjustment the screen height. Refer to Operating Instructions page 5.

12 Loosen the height adjustment handles on the board attachment frame.

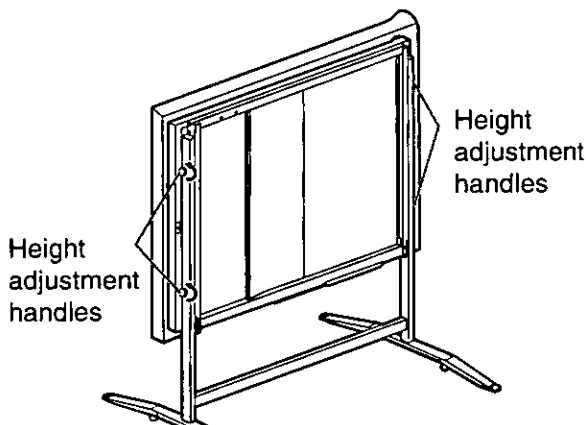

13 Hang the step frame on the center of the reinforce pipe.

Hold the center of the board attachment (lower) of the board attachment frame from the back of the screen unit and lift the board attachment frame by stepping on the step frame to lift the board attachment frame smoothly.

When lifting the board attachment frame, be sure to hold the handle in the center of the frame.

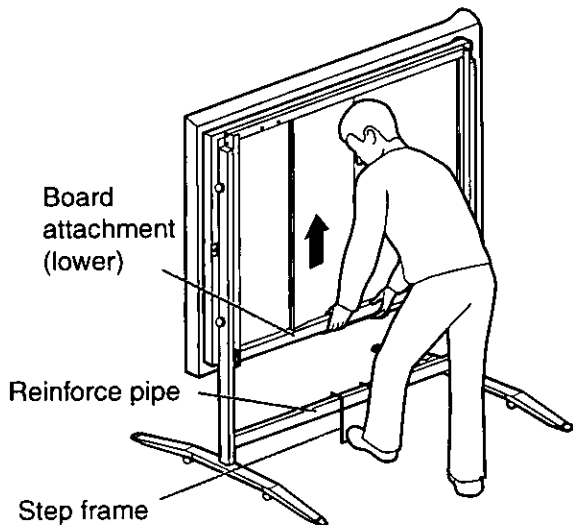

14 Hang the screen in the desired slots of the slide plates and tighten the handles.

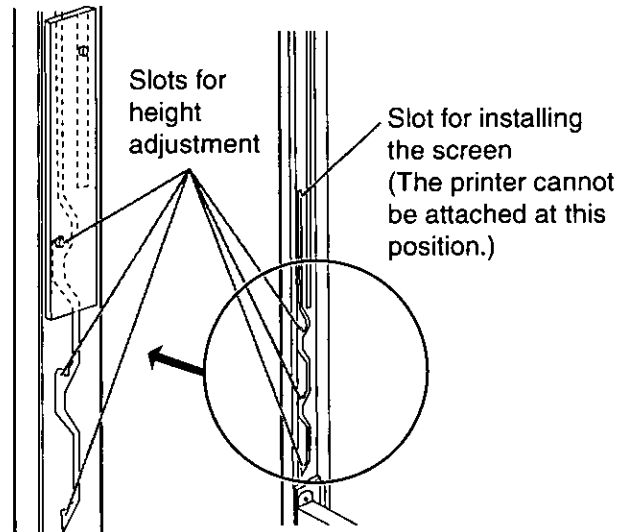

Caution

The screen can be adjusted at 4 levels.

- The lowest level of the board attachment frame is designed for the installation of the screen, so the printer cannot be attached at that level. Use the electronic board at upper 3 levels.
- Make sure to tighten the height adjustment handles firmly after adjusting the level of the screen.
- Confirm both of the screws are hung in the same height slots.
- Store the step frame by hanging it on the board attachment (upper).

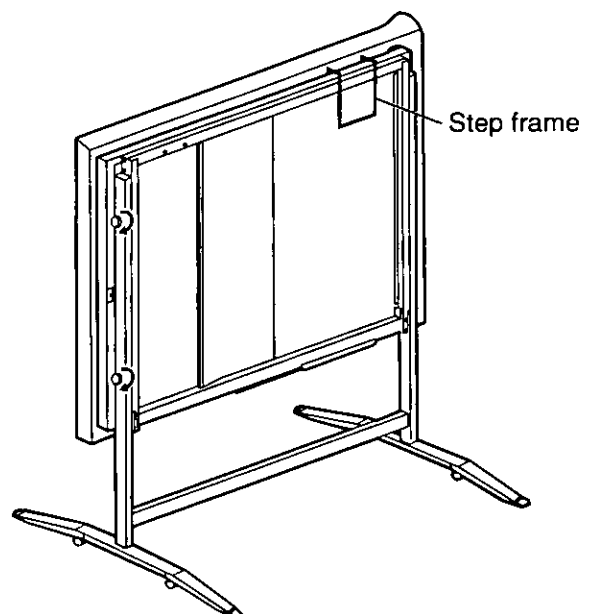

15 After hanging the screen, fix the stopper screw.

This prevents the user from adjusting the screen height at the lowest level by mistake.

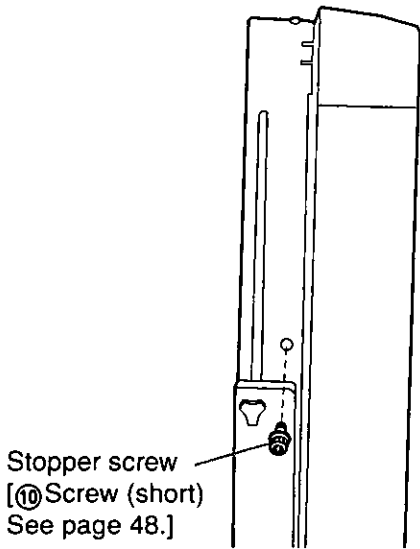

16 Attach the printer unit.

Hang the hooks of the printer unit on the square holes of the board attachment (lower).

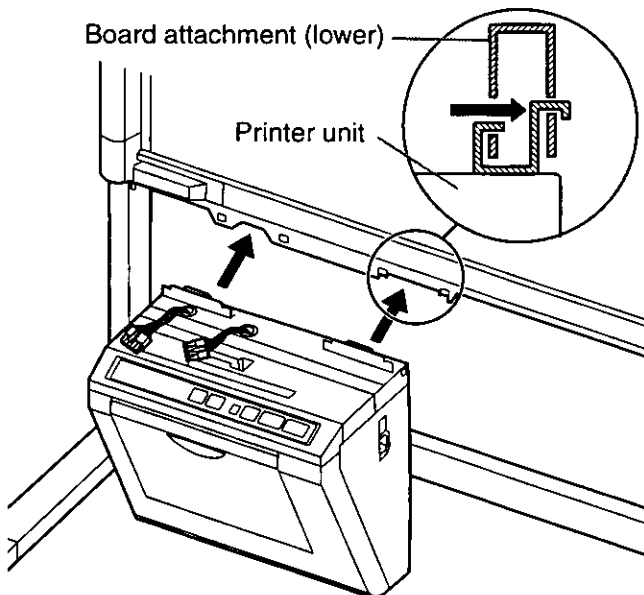

Caution

- When attaching the printer unit, make sure the cable is not caught between the metallic frame and the printer unit.

17 Tighten the screws for the printer.

Use four screws for the optional stand and two screws for the wall mounting.

■ Optional stand

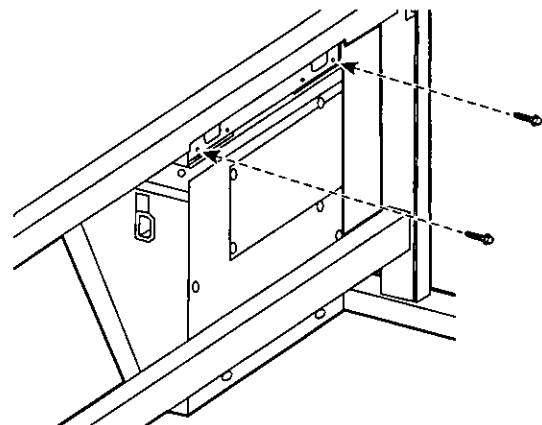
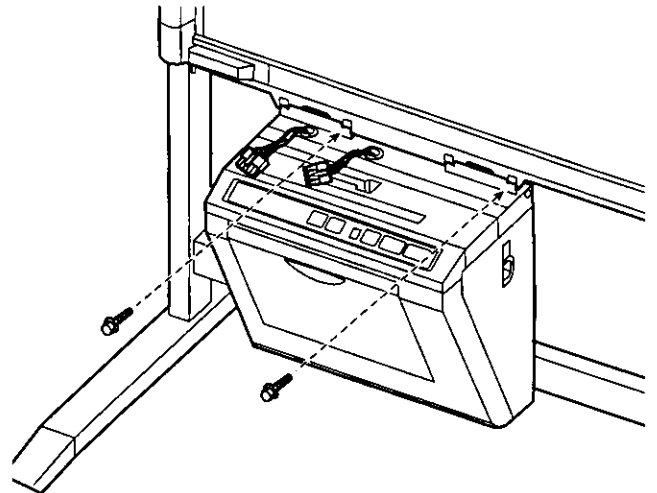

■ Wall-mounting

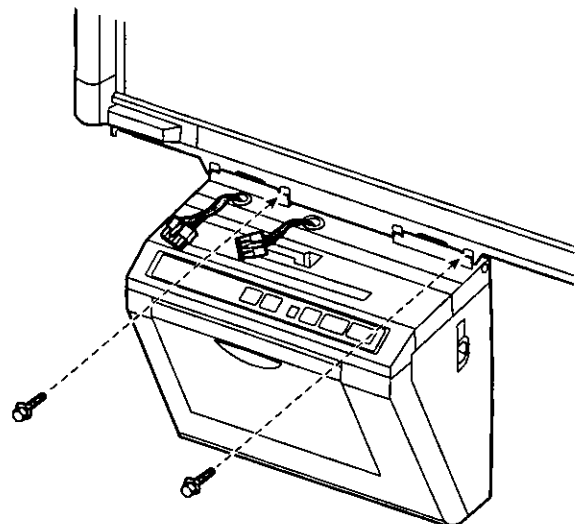

Assembling the Electronic Board

18 Connect the cables (2) to the screen panel connectors.

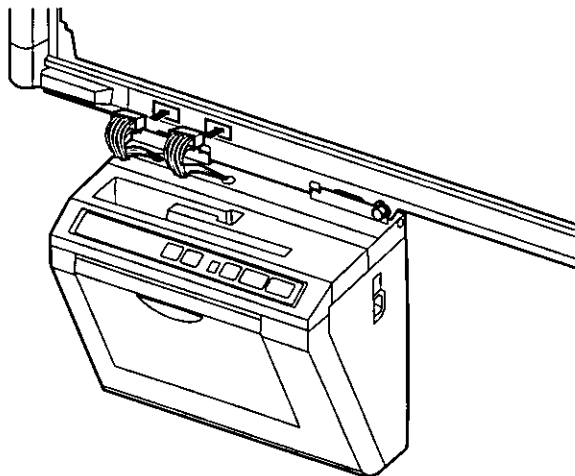

19 Remove the folding support screw on the front side of the screen unit, then store the folding support on the back side.

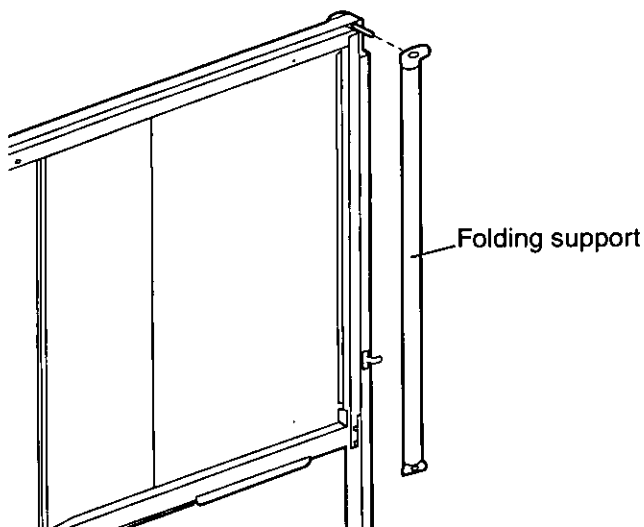
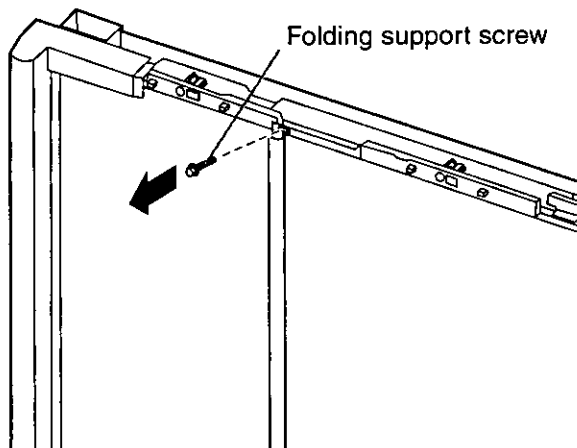

20 Attach the cover (upper).

Hook the cover with the projections on both sides, then cover the top of the board attachment (upper).

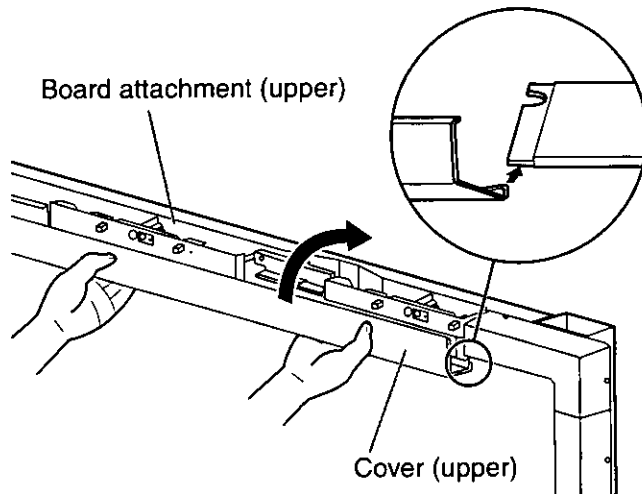

21 Store the shipping screws for fixing the screen panels, the screw for the folding frame and the wrench in the tool box on the top of the printer.

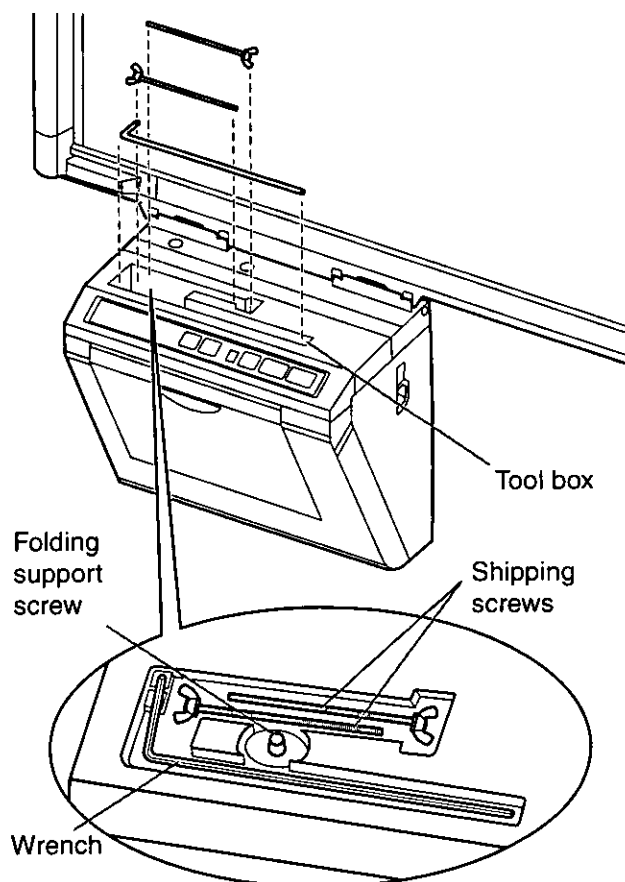

22 Attach the cover (lower).

- ① Push the cover in the direction of the arrow until it clicks.
- ② Fix the cover with the wing bolt.

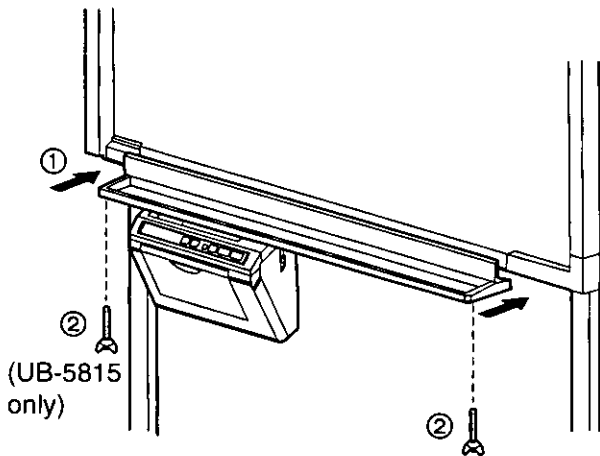

23 Attach the power cord.

Securely fit the supplied power cord into the AC inlet on the printer unit.

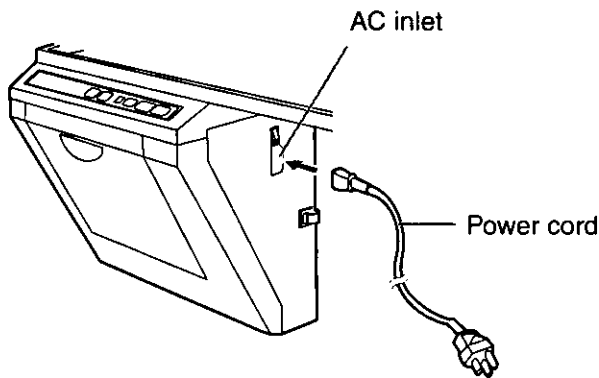

Caution

- The power cord should be held in the cord holder.

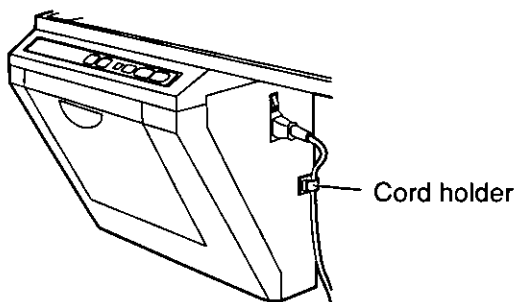

24 Attach the rear cover. (only for use of the optional stand)

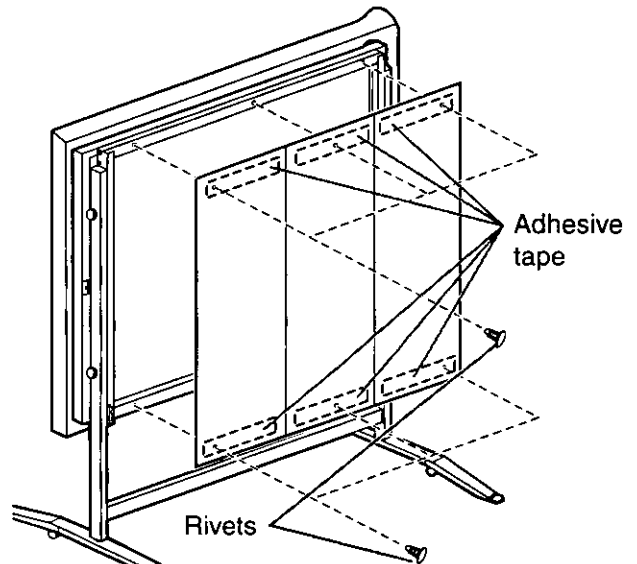

- After peeling off the cover sheets of the adhesive tapes, attach the rear cover to the board attachments (upper/lower) while matching the top edges of them. Then install the rivets
- The rear cover and rivets are supplied with the optional stand.

25 Wipe the screen film surface.

Soak a soft cloth with water, wring well, and wipe the screen film surface.

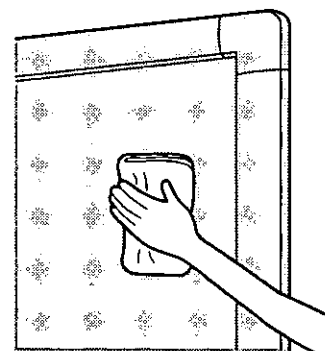

Caution









- Do not wipe the screen film surface with paint thinner, benzene, or cleaners that contain abrasives. Doing so may cause discoloration.
- Do not wipe the screen film surface with a dry cloth. Doing so may create static electricity.

26 Check the operations.

Refer to "Electronic Board Operations Check" on page 46.

Electronic Board Operations Check

After assembling the electronic board, perform the procedures presented in the following table to make sure it functions properly.

Step		Points to Check	
		Symptom	Solutions
1	Turn on the power switch.	"r" flashes after "g" lights up.	(Normal operation)
		(If not)	Check power cord and cables. (See step 23 on page 45 and step 18 on page 44.)
2	Open the printer door and attach the accessory thermal transfer film, then close the printer door. • Installing Thermal Transfer Film procedure (refer to the Operating Instructions page 10, 11)	"p" flashes.	(Normal operation)
		(If not)	Check thermal transfer film.
3	Open the paper cover and insert ordinary Letter test paper, then close the paper cover. • Loading Copy Paper procedure (refer to the Operating Instructions page 12, 13)	"i" lights up.	(Normal operation)
		(If not)	Check copy paper.
4	Open the printer door.	"d" flashes.	(Normal operation)
		(If not)	Check printer cables.
5	Close the printer door.	"i" lights up.	(Normal operation)
		(If not)	Check printer cables.
6	Press  .	Screen is fed.	(Normal operation)
		The screen film surface is not fed smoothly.	Contact the store or dealer from which the unit was purchased.
		There are strange noises.	
7	① Use the accessory marker to draw a large  filling the entire copyable area of the screen film surface. • Copyable area (refer to the Operating Instructions page 7) ② Press  twice. ③ Press  .	"3" lights up and three copies are made.	(Normal operation)
		Three copies are not made.	Contact the store or dealer from which the unit was purchased.
		The entire readable area is not printed.	
		There are strange noises or paper jams during the copying process.	
8	① Press  to move the screen film surface. Write letters, etc. with the marker. ② Press  once. ③ Press  .	The Contrast/Remaining Film indicator light is not turned on.	Contact the store or dealer from which the unit was purchased.
		The image is not copied properly.	
		There are strange markings on the copy sheet (e.g., stripes or lines).	
9	Press  once.	The Contrast/Remaining Film indicator light is not turned off.	Contact the store or dealer from which the unit was purchased.
10	Press  .	Two screens are not copied properly.	Contact the store or dealer from which the unit was purchased.

Repacking



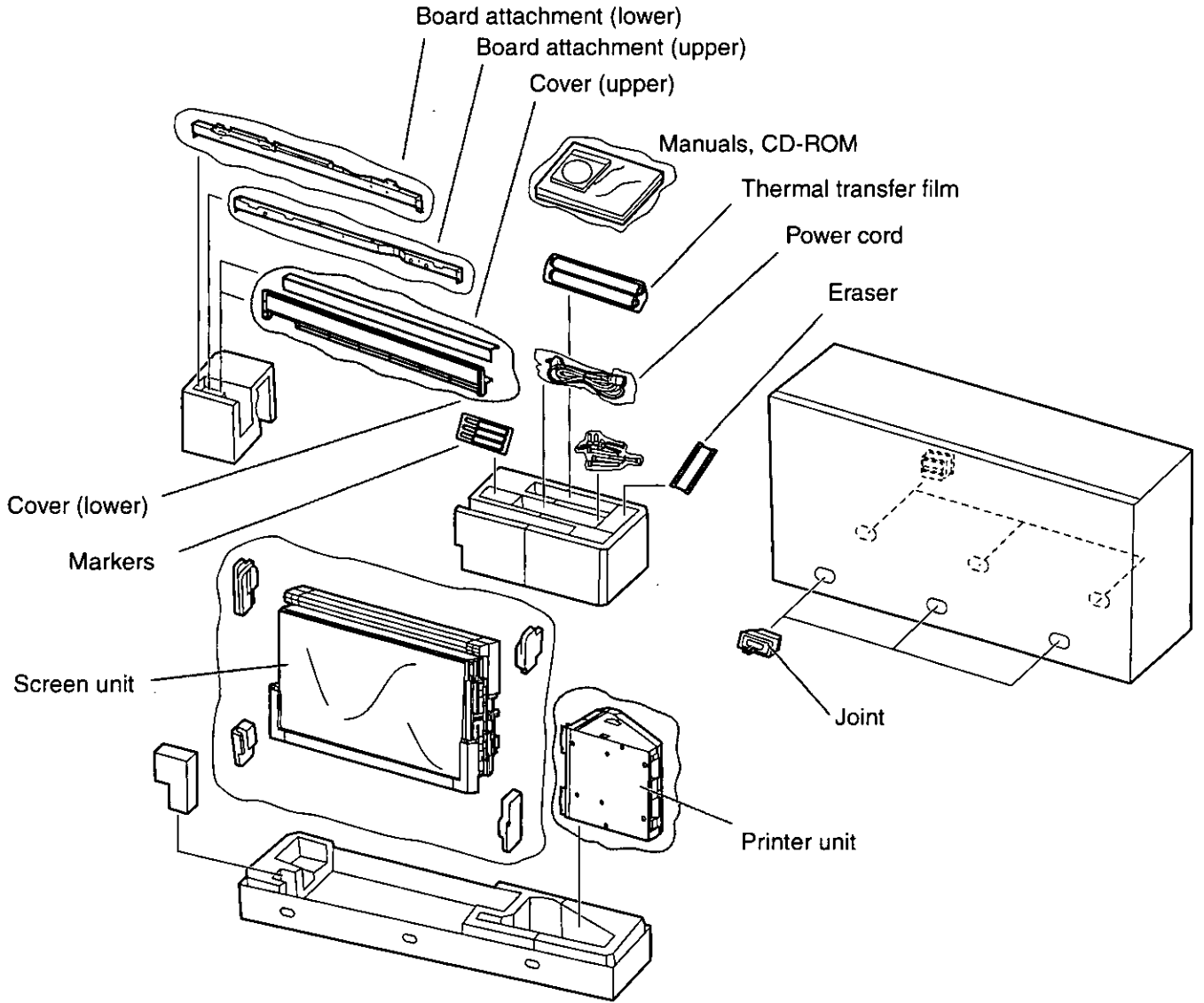







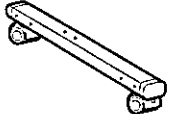

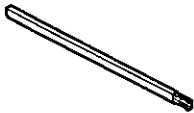



Perform Assembly Steps 2 through 24 in reverse to repack the electronic board and accessories. Use the joints to fasten the shipping box to the lower box.

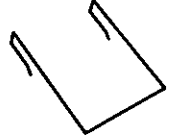

Assembling the Optional Stand (UE-608005)

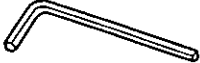
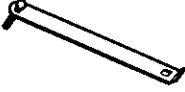
■ Accessories

The package box for the optional stand includes the parts noted below; please confirm that all parts are present before beginning installation

No.	Part name	Illustration	Q'ty	No.	Part name	Illustration	Q'ty
①	Base pipe		2	⑪	Screw		2
②	Reinforce pipe		1	⑫	Height adjustment handle		4
③	Extension pipe S (For UB-5315)		1	⑬	Nut		4
④	Extension pipe L (For UB-5815)		1	⑭	Cap		2
⑤	Side pipe		2	⑮	Step frame		1
⑥	Slide plate (Left)		1	⑯	Fall-prevention extension leg		4
⑦	Slide plate (Right)		1	⑰	Wrench		1
⑧	Fixing plate		2	⑱	Rivet		6
⑨	Screw (long)		12	⑳	Washer		8
⑩	Screw (short)*		11				

The accessory Wrench is required when disassembling the electronic board; please store it carefully for future use.

*A screw (short) ⑩ is used for the stopper screw of step 15 on page 43.

●Before assembly, be sure to lock the casters.

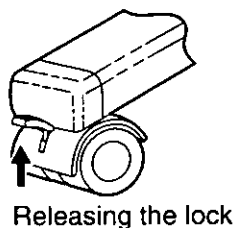
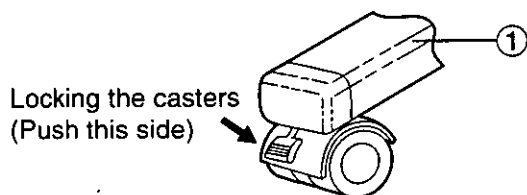

■ Assembly

1 Assembling the stand

■ Assembling the fall-prevention extension legs

The fall-prevention extension legs are effective in increasing the safety of the electronic board.

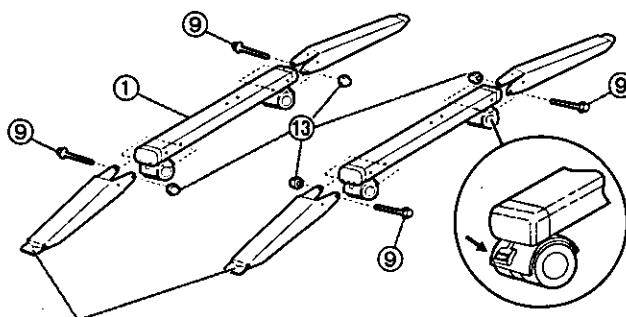

⑯ Fall-prevention extension legs

- Caster locks are attached to the back side.

Caution

- Install and always set the fall-prevention legs when using the stand.
- When tightening the screw ⑨, hold the nut ⑬ with pliers.

■ Assembling the stand

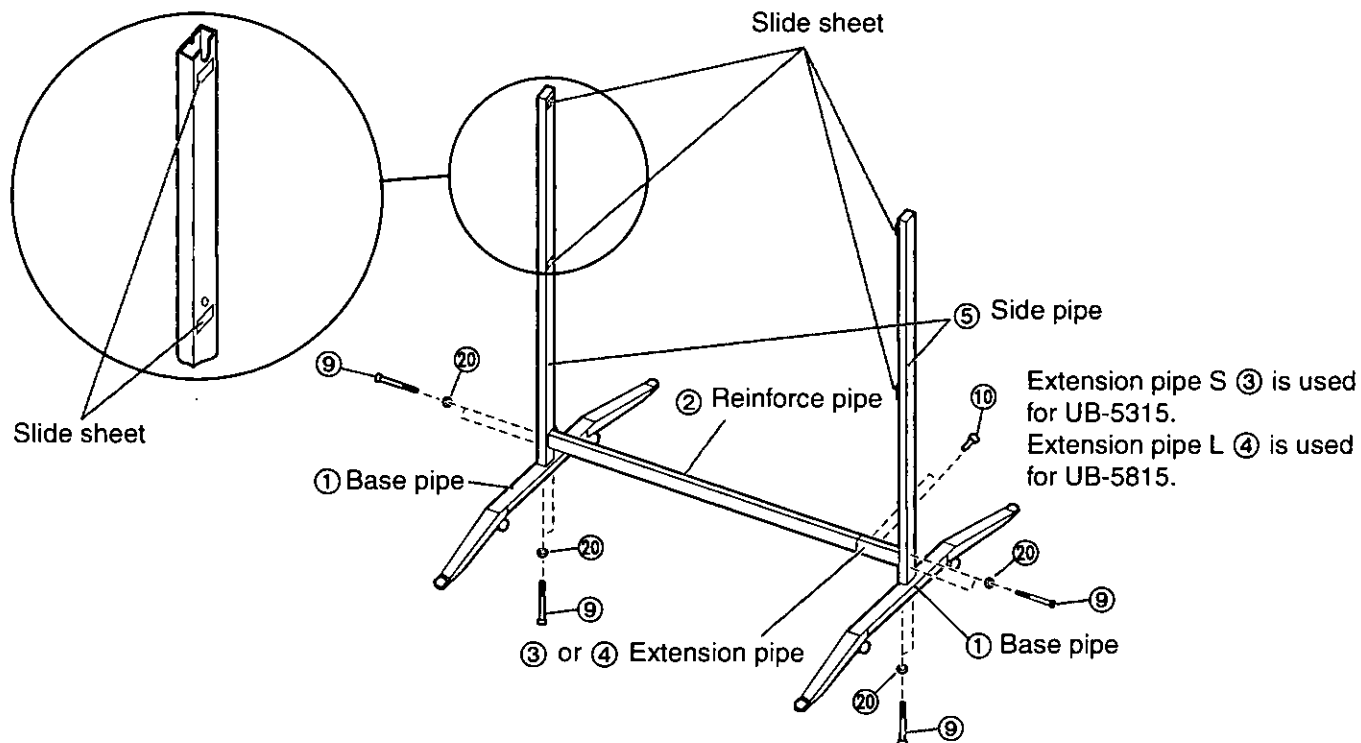

- Assemble the side pipes with the slide sheets facing inside.

Assembling the Optional Stand (UE-608005)

2 Assembling the board attachment frame

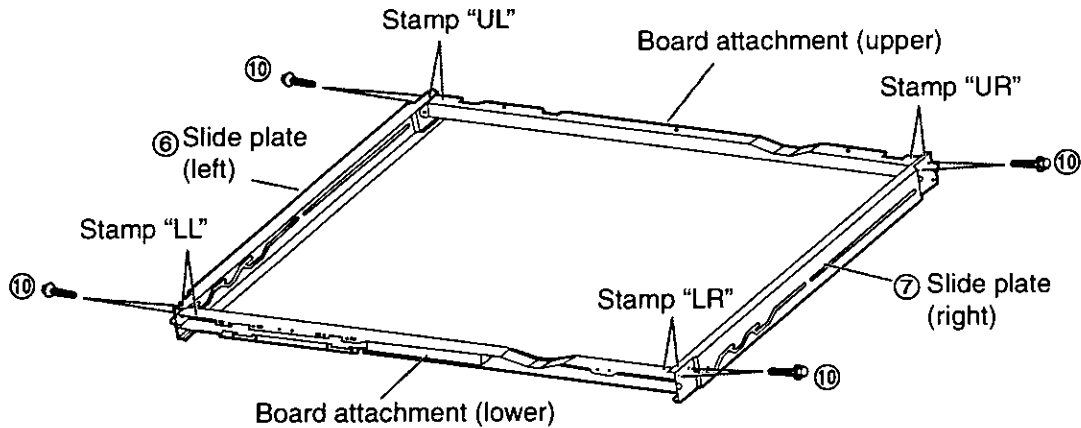

- The board attachments (upper and lower) are supplied with the electronic board.
- Place the board attachments and the slide plates with their stamps facing up and assemble them matching their same stamps.

3 Attach the board attachment frame to the stand.

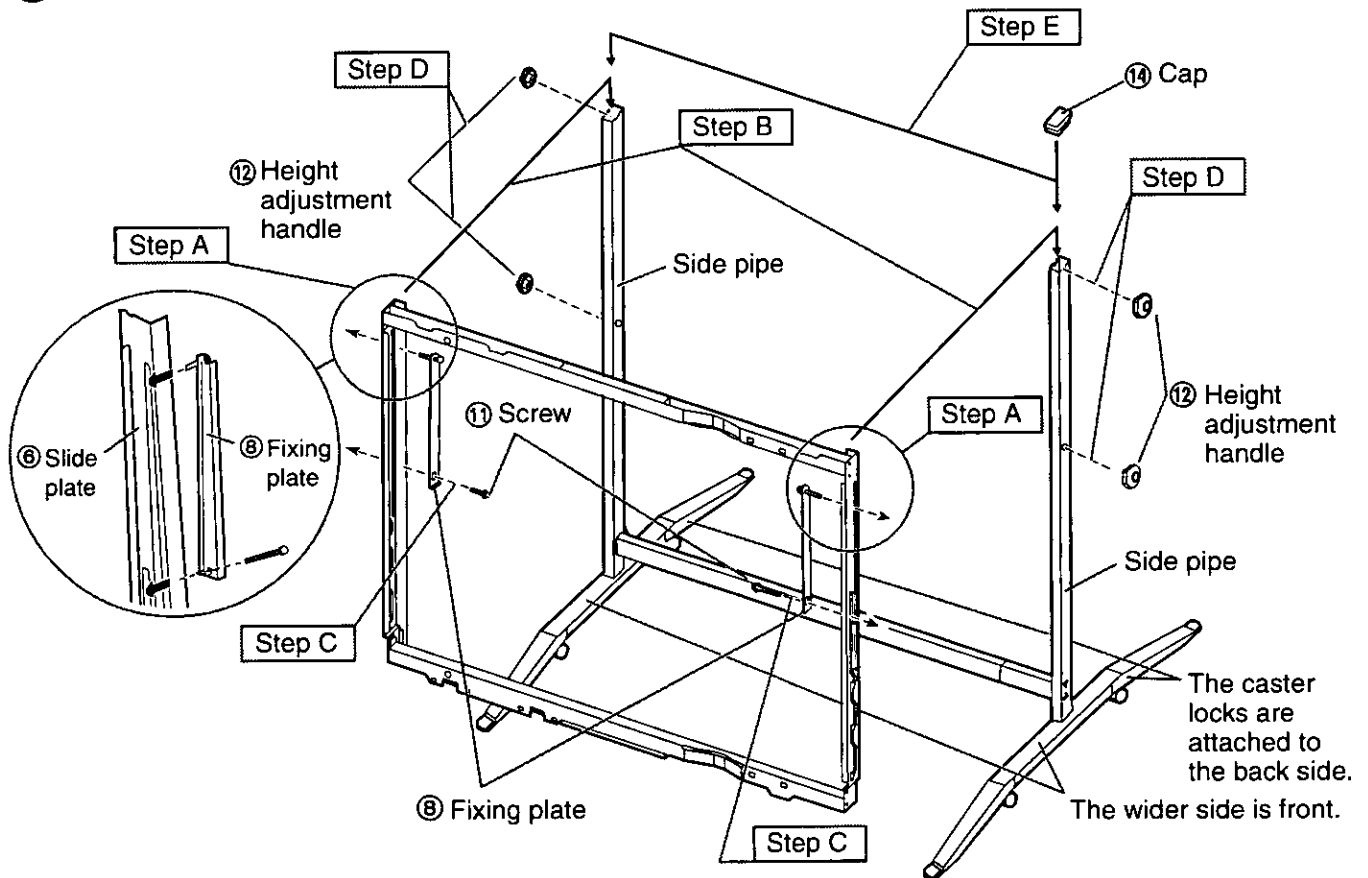

Details of the procedures are as follows.

Step A Attach the fixing plate ⑧ to the board attachment frame.

Assembling the Optional Stand (UE-608005)

Step B Place the screws with the board attachment frame in the grooves of the side pipes.

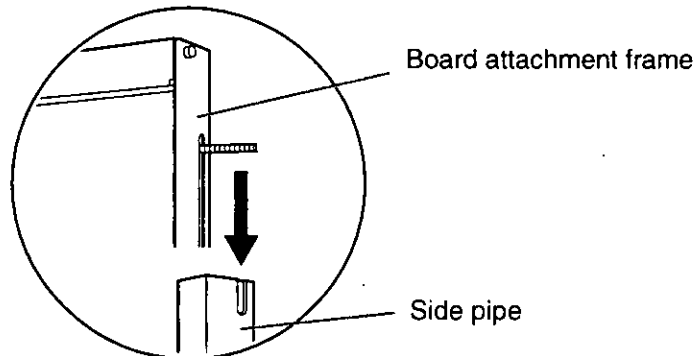

- When the side pipe leans to the inside, stand it up and attach the board attachment frame.

Step C Insert the screws ⑪ into the side pipes from the inside.

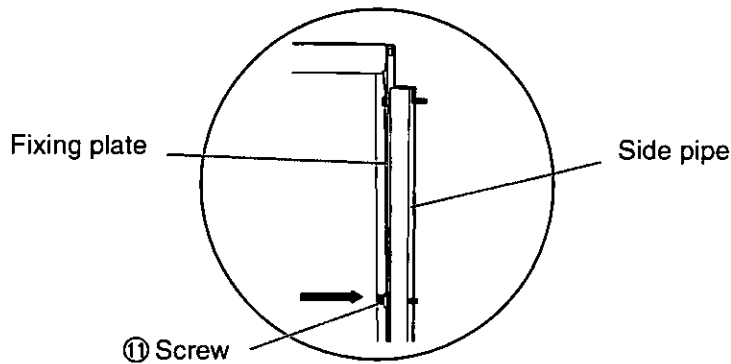

Step D Install and secure the height adjustment handles ⑫.

Step E Fix the caps ⑭ to the side pipes.

4 Assemble and install the electronic board.

Refer to pages 39 to 45.

5 Insert and keep the wrench in the holder on the cover lower.

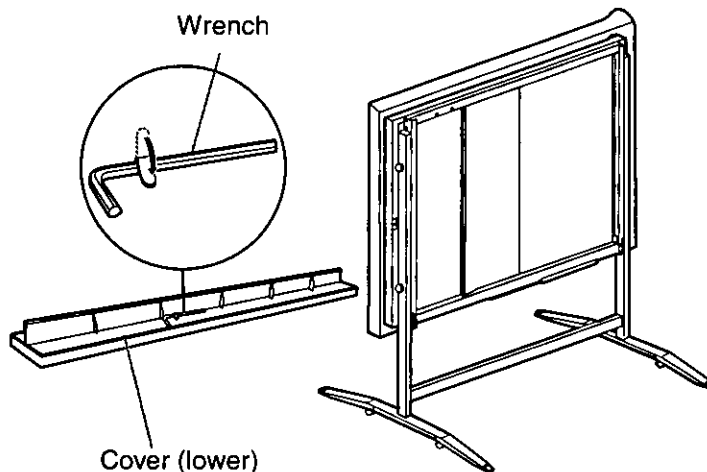

Wall-mounting

■ Wall-mounting fixture

The wall-mounting fixture includes the board attachment (upper and lower) supplied with the unit. Before attempting installation of this wall-mounting fixture, we strongly recommend consulting with the building manager, engineer, or architect. The installer needs to know the type of construction used for the wall intended for this installation and the location of wall studs. Selection of hardware is critical for safe wall-mounting, and depends on the nature of wall construction. Installation should not occur until this consultation takes place.

Caution

- **Do not attach the electronic board to mortared walls. Accidental electric leakage from the wall-mounting fixture bolts to metal laths or wire laths can cause heat, smoke or a fire.**

I. Tools required:

A minimum of four (4) pieces of appropriate wall-support hardware (molley, toggle, etc.)

NOTE: THIS HARDWARE MUST BE LOCALLY PROCURED. IT IS NOT INCLUDED IN THE PRODUCT.

Drill (and drill bit of correct size) for hardware installation

Screw driver (Both phillips (+) and slotted (-) will be required.)

Tape measure

Tape or thumb-tacks (2 pcs)

Bubble type level

II. Pre-requisites

1. Before installation, make sure that the wall intended for installation is capable of supporting flush-mounted.
UB-5315 is 80 kgf (176 lbs.).
UB-5815 is 95 kgf (209 lbs.).
2. The position of the intended installation is of adequate size for the selected Panaboard.
UB-5315 is 1,334 mm (H) × 1,372 mm (W) [4' 4¹/₂" (H) × 4' 6" (W)].
UB-5815 is 1,334 mm (H) × 1,735 mm (W) [4' 4¹/₂" (H) × 5' 8⁵/₁₆" (W)].
3. An outlet is within 3 m (9' 10¹/₈"), and not located behind the Panaboard.

■ Wall-mounting procedure

- 1 Confirm that the wall is strong enough to support the weight of the electronic board.

Caution

The wall must be capable of supporting at least
 784N [80 kgf (176 lbs.)] for UB-5315
 931N [95 kgf (209 lbs.)] for UB-5815.

- 2 Tape the wall-mounting template on the wall.

- When taping the template on the wall, make sure it is level.

- 3 1) Drill holes in the wall for the wall-mounting fixtures.

- 2) After removing the wall-mounting template, attach the wall-mounting fixtures with the appropriate wall-mounting hardware.

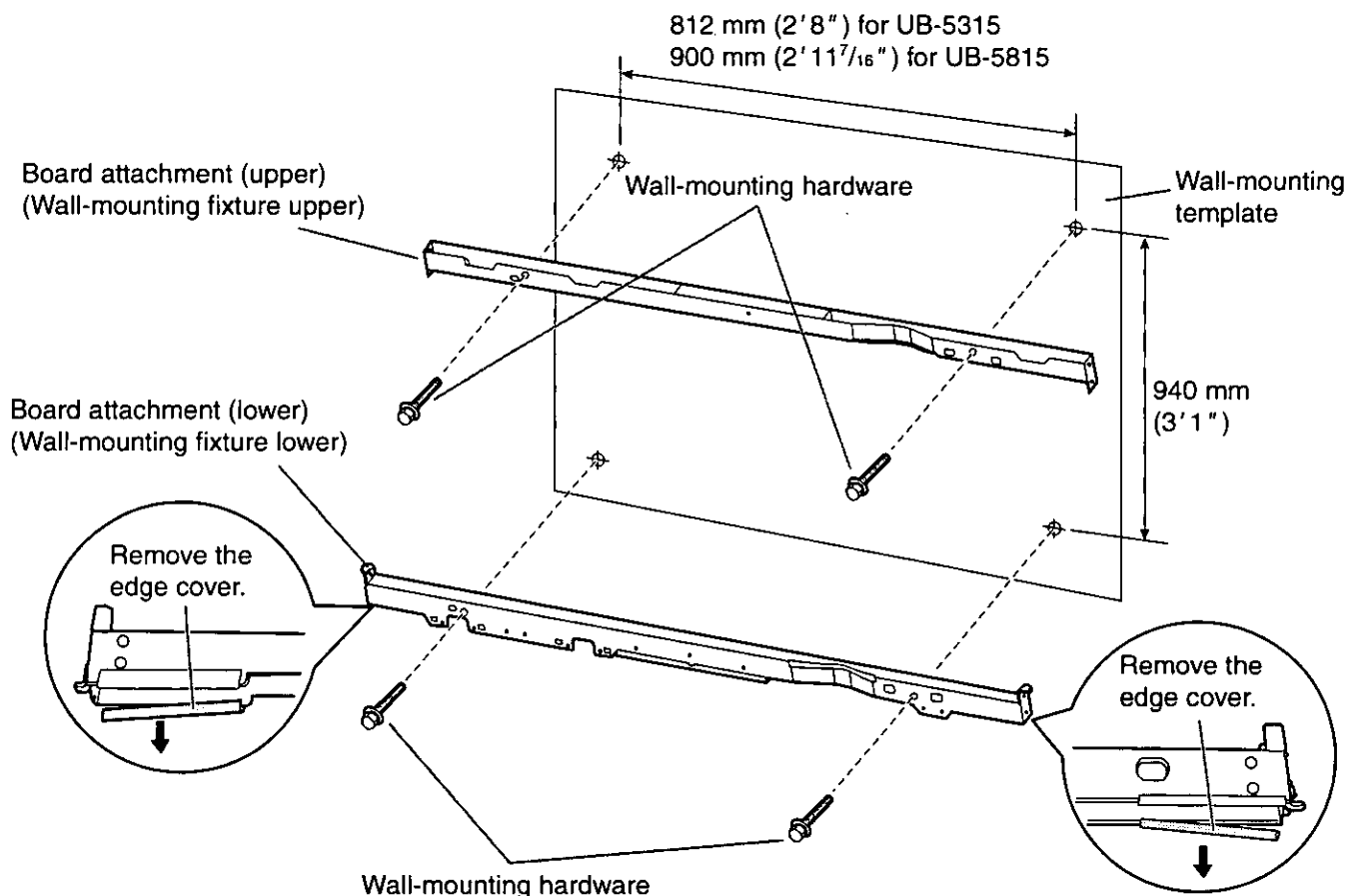

- Refer to the section "Attaching the wall-mounting fixtures" (page 54) for drilling in the wall and attaching the mounting fixtures.
- Refer to steps 2 to 23 on pages 39 to 45 for attaching the printer and the screen.

Wall-mounting

■ Attaching the wall-mounting fixtures

The electronic board must be mounted with the method most suited to the material of the wall. Three methods are presented here. (Other options may be available in your area.)

● Attaching to metal or concrete walls

Stud plugs (sold in stores) are needed.

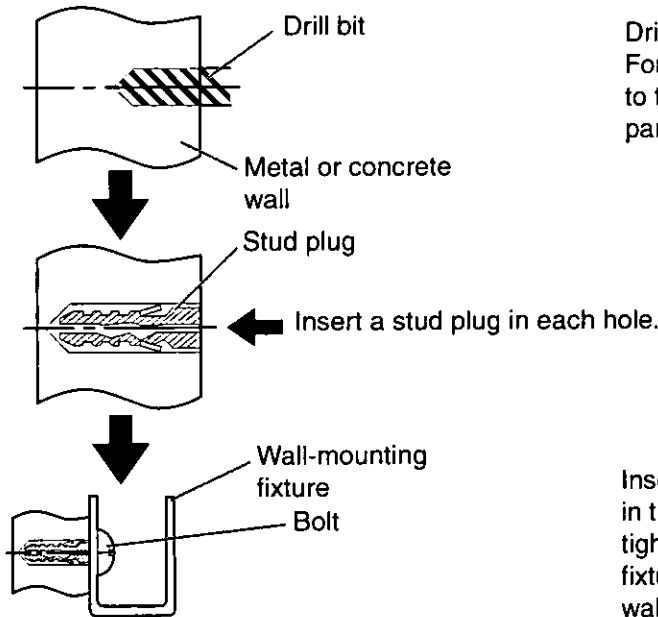

Drill four holes in the wall. For the correct hole size, refer to the instructions for the particular stud plugs used.

Insert each bolt through a hole in the wall-mounting fixture and tighten until the wall-mounting fixture is securely fixed to the wall.

● Attaching to plasterboard walls

Split-wing toggles (sold in stores) are needed.

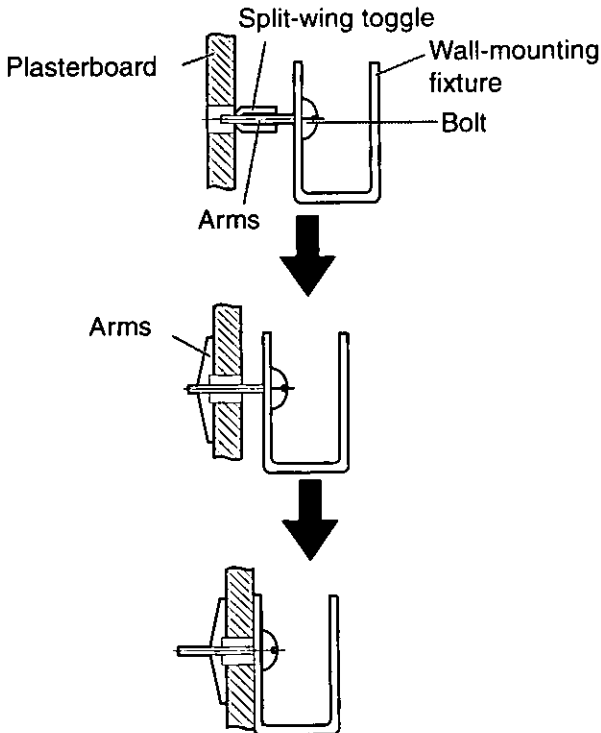

Insert each bolt through a hole in the wall-mounting fixture and into the hole in the wall beneath so that the arms of the split-wing toggle are horizontal. For the correct hole size, refer to the instructions for the particular split-wing toggles used.

After the arms expand, pull the wall-mounting fixture out until the arms of the split-wing toggle grip firmly into the wall.

Tighten each bolt until the wall-mounting fixture is securely fixed to the wall.

● Attaching to wooden walls

Use wood screws (sold in stores).

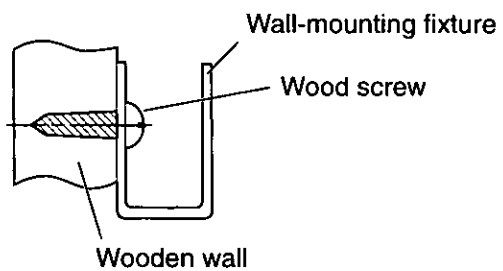

For the correct hole size, refer to the instructions for the particular wood screws used.

These Operating Instructions are printed on recycled paper.

Panasonic Digital Document Company
A Unit of Matsushita Electric Corporation of America
Two Panasonic Way, Secaucus, New Jersey 07094

© 2002-2003 Panasonic Communications Co., Ltd.

Printed in Japan



PJQXB0044ZA K0303M0